

---

**STANLEY**

# Oscar Solid Fuel Stove

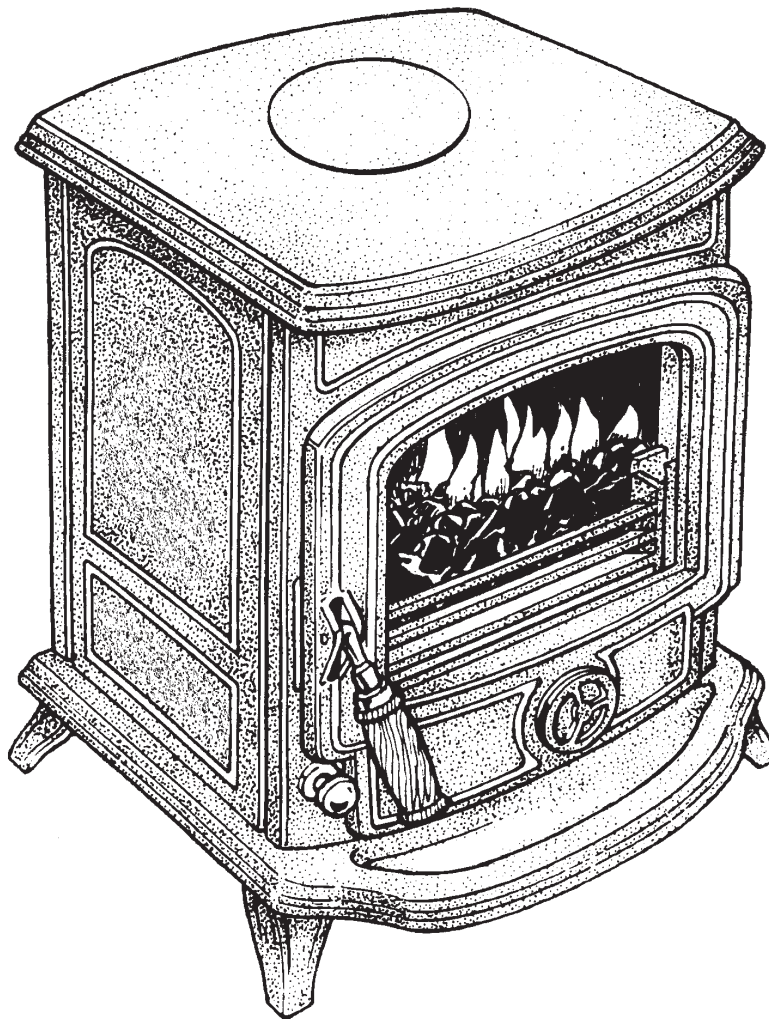

This appliance is hot while in operation and retains its heat for a long period of time after use. Children, aged or infirm persons should be supervised at all times and should not be allowed to touch the hot working surfaces while in use or until the appliance has thoroughly cooled.

***INSTALLATION AND OPERATING INSTRUCTIONS***

---

---

## TABLE OF CONTENTS

	<b>PAGE NO.</b>
1. General .....	3
2. Pre Installation Assembly .....	3
3. Flues .....	3
4. Chimney .....	3
5. Top Flue Exit .....	4
6. Rear Flue Exit .....	4
7. Down Draughts .....	4
8. Ventilation & Combustion Air Requirements .....	5
9. Location .....	5
10. Clearance to Combustibles .....	5
11. Floor Protection .....	6
12. Stove Dimensions .....	6
13. Lighting .....	6
14. Primary Air Settings .....	6
15. Recommended Fuels .....	6
16. Outputs .....	6
17. Re-Fuelling .....	6
18. Important Notes .....	7
19. Lighting .....	8
20. De-Ashling .....	9
21. Disposal of Ash .....	9
22. Maintenance .....	9
23. Chimney Cleaning .....	9
24. Fire Safety .....	9
25. Glass - Cleaning & Replacement .....	9
26. Enamel Cleaning .....	10
27. Exploded View .....	10
28. Installation Check List .....	11

# OSCAR SOLID FUEL STOVE INSTALLATION & OPERATING INSTRUCTIONS

## GENERAL

When installing, operating and maintaining your Oscar Stove respect basic standards of fire safety. Read these instructions carefully before commencing the installation. Failure to do so may result in damage to persons or property. Consult your local Municipal office and your insurance representative to determine what regulations are in force. Save these instructions for future reference.

**The complete installation must be done in accordance with current Standards and Local Codes. It should be noted that the requirements and these publications may be superseded during the life of this manual.**

## PRE-INSTALLATION ASSEMBLY

1. After removing the stove from its pack, open the fire door and remove all contents from the ashpan.
2. Fit the fire door handle using the screw provided.
3. Remove the stove from the pallet and position it in the final installation position (See Location & Clearance to Combustibles Section).

## FLUES

Flues should be vertical wherever possible and where a bend is necessary, it should not make an angle of more than  $37.5^{\circ}$  with the vertical. Horizontal flue runs should be avoided except in the case of a back outlet connection where the length of the horizontal section should not exceed 300mm.

## CHIMNEY

The Oscar is a radiant room heater and must be connected to a chimney of the proper size and type. The chimney must have a cross-sectional area of at least 20 square inches 124 sq.cm or a diameter of at least 5" (125mm). Never connect to a smaller size chimney. Do not connect to a chimney serving another appliance. Minimum chimney height 15' (4.1 meters) from floor on which stove is installed. A flue that has proved to be unsatisfactory, particularly with regard to down draught should not be used for venting this appliance until it has been examined and any faults corrected. An existing masonry chimney should be inspected and if necessary repaired by a competent mason or relined using an approved lining system. The stove must be connected to a

chimney with a minimum continuous draught of 0.06 w.g. Poor draught conditions will result in poor performance.

All register plates, restrictor plates, damper etc., which could obstruct the flue at a future date should be removed before connecting this appliance.

If connecting to an existing chimney with a flue diameter of more than 6" it is necessary to line the flue using a suitable stainless steel flue liner.

Where a masonry chimney is not available a proprietary type of 5"/6" - 12.5/15cm twin wall, fully insulated pipe may be used. The pipe must terminate at a point not lower than the main ridge of adjacent outside obstructions. With such installation, access to the chimney must be provided for cleaning purposes. (See Fig.1)

Fig.1

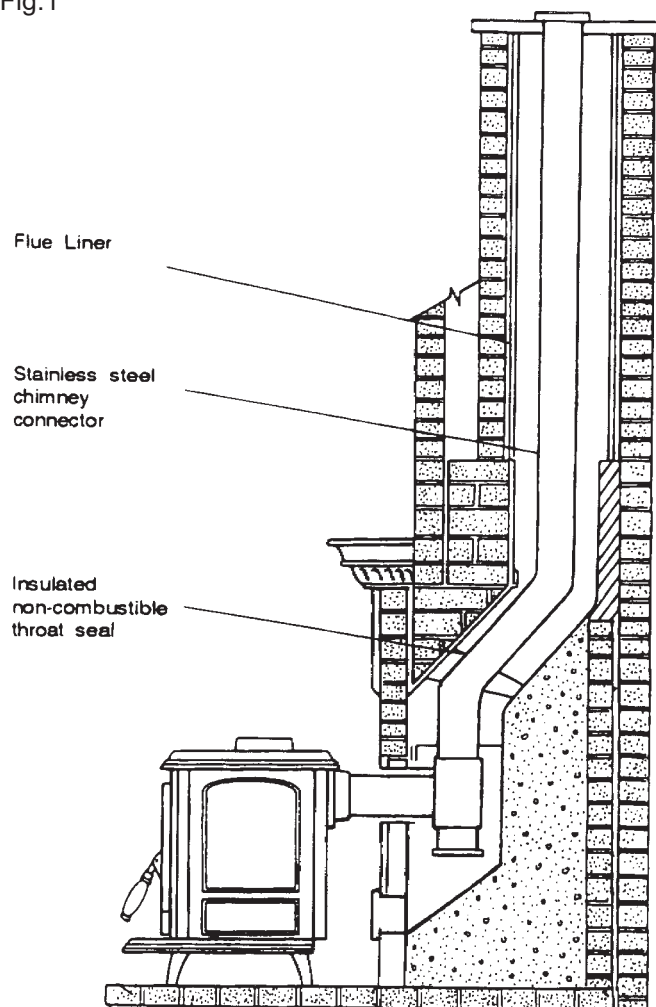

When flue piping passes through closure plate with sliding door, ensure that the pipe continues up and is ultimately connected to the flue liner and well sealed with fire cement.

## TOP FLUE EXIT

For the top outlet configuration, remove the blanking plate (part no.10) from the hob, remove the flue spigot (part no.11) from the back plate and fix it to the hob. Fix the outlet blanking plate to back plate (see Fig. 2). Push the flue outlet connector pipe (not supplied) into the flue spigot and cement into place using approved fire cement ensuring that no cement blocks the flue passageway.

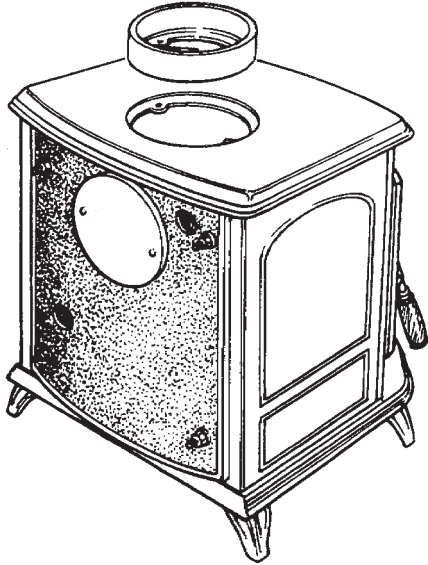

Fig.2

## REAR FLUE EXIT

Push the flue connector pipe (not supplied) into the flue spigot and cement into place using approved fire cement ensuring that no cement blocks the flue passageway (see Fig.3).

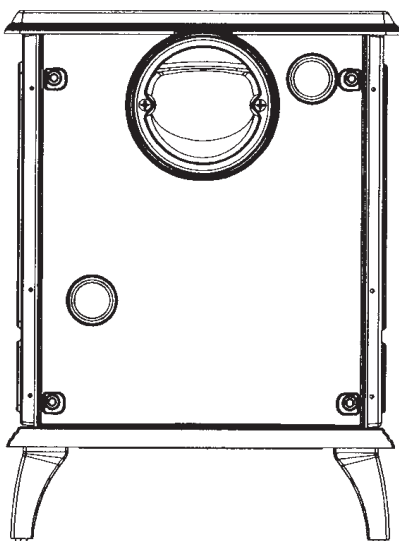
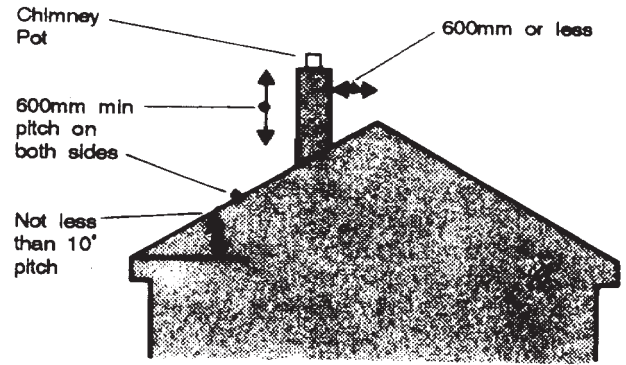

Fig.3

Fig.4



## DOWN DRAUGHTS

However well designed constructed and positioned, the satisfactory performance of the flue can be adversely affected by down draught caused by nearby hills, adjacent tall buildings or trees. These can deflect wind to blow directly down the flue or create a zone of low pressure over the terminal.

A suitable anti-down draught terminal or cowl will usually effectively combat direct down blow but no cowl is likely to prevent down draught due to a low pressure zone. (See Fig.5)

Fig.5

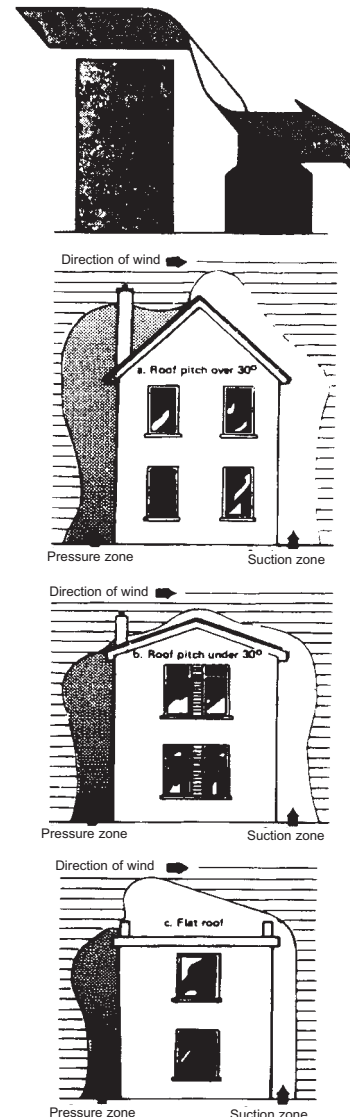

## VENTILATION AND COMBUSTION AIR REQUIREMENTS

The minimum effective air requirement for this appliance is 132 cm<sup>2</sup>. When calculating combustion air requirements for this appliance use the following equation: 550mm<sup>2</sup> per each kW of rated output above 5 kW should be provided, where a flue draught stabiliser is used the total free area shall be increased by 300mm<sup>2</sup> for each kW of rated output.

If there is another appliance using air fitted in the same or adjacent room, it will be necessary to provide an additional air supply.

All materials used in the manufacture of air vents should be such that the vent is dimensionally stable, corrosion resistant, and no provision for closure.

The effective free area of any vent should be ascertained before installation. The effect of any grills should be allowed for when determining the effective free area of any vent.

Air vents direct to the outside of the building should be located so that any air current produced will not pass through normally occupied areas of the room.

An air vent outside the building should not be located less than the dimensions specified within the Building Regulations and B.S. 8303: Part 1 from any part of any flue terminal. These air vents must also be satisfactorily fire proofed as per Building Regulations and B.S. 8303: Part 1.

Air vents in internal walls should not communicate with bedrooms, bedsits, toilets, bathrooms or rooms containing a shower.

Air vents traversing cavity walls should include a continuous duct across the cavity. The duct should be installed in such a manner as not to impair the weather resistance of the cavity.

Joints between air vents and outside walls should be sealed to prevent the ingress of moisture. Existing air vents should be of the correct size and unobstructed for the appliance in use. If there is an extraction fan fitted in the room or adjacent rooms where this appliance is fitted, additional air vents will be required to alleviate the possibility of spillage of products of combustion from the appliance/flue while the fan is in operation. Refer to B.S. 8303 Part 1.

Where such an installation exists, a test for spillage should be made with the fan or fans and other appliances using air in operation at full rate, (i.e. extraction fans, tumble dryers) with all external doors and windows closed.

If spillage occurs following the above operation, an additional air vent of sufficient size to prevent this occurrence should be installed.

## LOCATION

There are several conditions to be considered in selecting a location for your Oscar Stove.

- Position in the area to be heated - central locations are usually best.
- Allowances for proper clearances to combustibles.

## CLEARANCE TO COMBUSTIBLES

Side wall to stove	22" 560mm
Back wall to stove	16.5" 420mm
Ceiling to horizontal connector	18" 460mm
Corner	15" 380mm
Mantle clearance	27" 690mm
Side trim, which extends less than 2" from the face of the fireplace	15.5" 395mm
Brick wall minimum clearance	

Fig.6

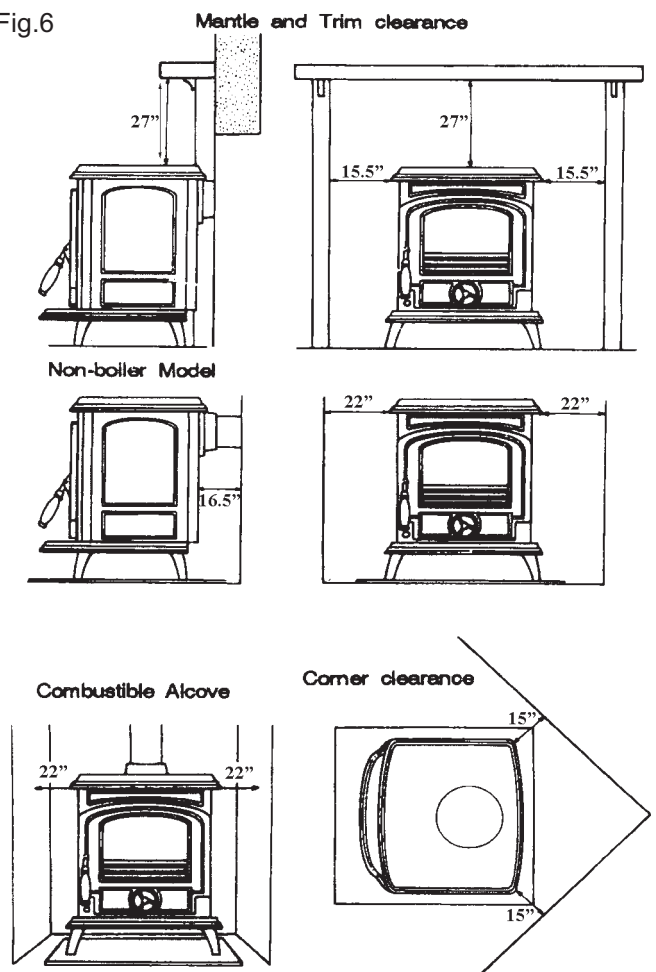

The connector may pass through walls or partitions constructed of combustible materials provided the connector is either listed for wall pass-through or is routed through a device listed for a wall pass-through and is installed in accordance with the conditions of the listing. Any unexposed metal that is used as part of a wall pass-through system is exposed to flue gases shall be constructed of stainless steel or other equivalent material that will resist corrosion, softening, or cracking from flue gas at temperatures up to 982°C.

## FLOOR PROTECTION

When installing this heater on a combustible floor, a floor protector, consisting of a layer of non-combustible material at least 3/8" thick or 1/4" thick covered with 1/8" sheet metal is required to cover the area under the heater and extend to at least 18" at the front and 8" to the sides and rear. This will provide protection from sparks and embers which may fall out from the door when stoking or fuelling. (See Fig.7)

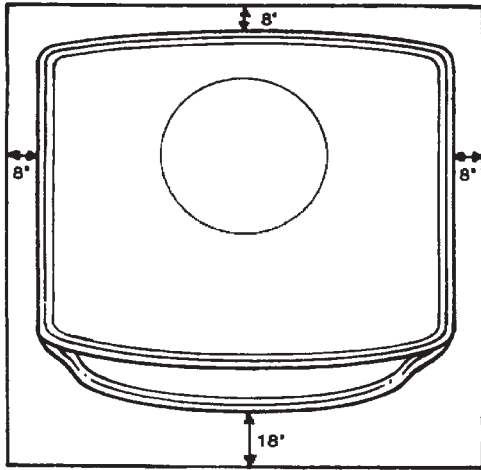

Fig.7

## STOVE DIMENSIONS

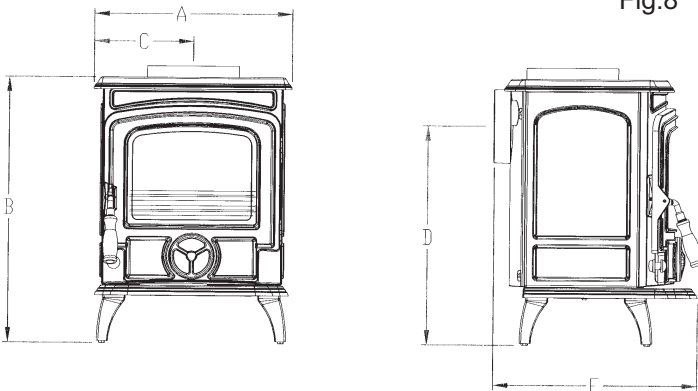

Fig.8

Dimensions	A	B	C	D	E
Metric (mm)	425	607	225	515	430
Imperial (inches)	17 <sup>3</sup> / <sub>8</sub>	23 <sup>7</sup> / <sub>8</sub>	8 <sup>7</sup> / <sub>8</sub>	20 <sup>1</sup> / <sub>4</sub>	16 <sup>7</sup> / <sub>8</sub>

## LIGHTING

Check that all dampers and catches are operating correctly and ensure that all flue connections are thoroughly sealed.

## PRIMARY AIR SETTINGS

The spin valve (Part No. 22, located at the bottom end of the door - Part No. 21) controls the primary and window wash air supply to the stove. For maximum heat output and burn rate rotate the spin valve (Part No. 22) in an anticlockwise direction and for a minimum heat output and burn rate rotate the spin

valve clockwise until fully closed. You will soon learn spin valve settings to best suit your requirements. (See Fig.9)

Fig.9

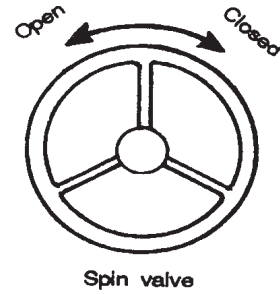

## RECOMMENDED FUELS

Bituminous coal, Anthracite, smokeless fuels, peat briquettes and seasoned wood. Do not use fuels with a Petro-coke ingredient.

The stove output levels are assessed on standard House Coals of good quality (Grade A).

Reduced outputs will result when fuels of lower calorific values are used.

All fuels should be stored under cover and kept as dry as possible prior to use.

## OUTPUTS

	BTU's	kW
Maximum	31,500	9.25
Non Boiler average to space	23,900	7.0

## Stove Weight:

Gross	Net
100 kgs	87kgs

## RE-FUELLING

Riddle the fire by connecting the grate operating tool onto the rocker connection located at the bottom front of the stove, then gently pull and push the rocker arm until all dead ash has fallen through into the ashpan. Before opening the door, open the spin valve by turning it anti-clockwise, as this will help to eliminate any smoke or fly ash resident in the combustion chamber. Add fuel to fire, close fire door and re-set spin valve to required setting. (See Fig.10)

Fig.10

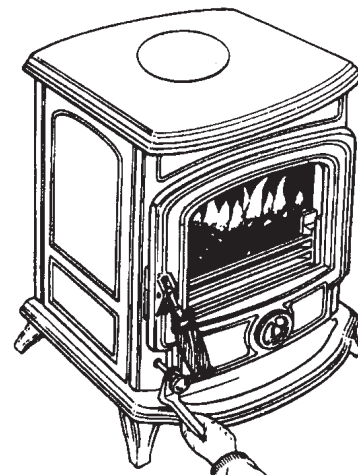

---

## IMPORTANT NOTES

Now that your Stanley solid fuel Stove is installed and no doubt you are looking forward to many comforts it will provide, we would like to give you some tips on how to get the best results from your stove.

1. We would like if you could take some time to read the operating instructions/hints, which we are confident, will be of great benefit to you.
2. Do not burn fuel with a high moisture content, such as a damp peat or unseasoned timber. This will only result in a build up of tar in the stove and in the chimney.

<b>FUEL CALORIFIC VALUES - SOLID FUELS</b>		
Anthracite 25-50mm	C.V.: 8.2kW/Kg	14,000 BTUs/lb
House Coal 25-75mm	C.V.: 7.2kW/Kg	12,000 BTUs/lb
Timber - Firebox size	C.V.: 5.0kW/Kg	8,600 BTUs/lb
Peat Briquettes	C.V.: 4.8kW/Kg	8,300 BTUs/lb
Bog Peat	C.V.: 3.4kW/Kg	6,000 BTUs/lb

3. **CLEAN THE FLUE-WAYS OF THE STOVE EVERY WEEK AND ENSURE THAT THERE ARE NO BLOCKAGES. PLEASE REFER TO MANUAL FOR INSTRUCTIONS.**
4. Before loading fresh fuel into the firebox, riddle fully to remove all ashes this will allow better and cleaner burning. See Re-Fuelling Section Page 6.
5. Never allow a build up of ashes in the ash pan, as this will cause the grate to burn out prematurely.
6. Avoid slow burning of damp or unseasoned fuel as this will result in tarring flue ways and chimney i.e. peat or timber.
7. Allow adequate air ventilation to ensure plenty of air for combustion.
8. Do not burn rubbish/household plastic.
9. Clean the chimney at least twice a year.
10. Burning soft fuels such as timber and peat will stain the glass. Regular cleaning will prevent permanent staining.
11. Keep all combustible materials a safe distance away from unit, please see section for clearances to combustibles.
12. For safety reasons never leave children unaccompanied while stove is in use.
13. Avoid contact with unit when in use as stove reaches very high operating temperatures.

---

## LIGHTING

**IMPORTANT:** The first few fires should be relatively small to permit the refractory to set properly and to season the stove.

1. Before lighting the stove, ensure that any build-up in the firebox has been removed and that the ashpan has been emptied.
2. Open the spin valve (Part No. 22) by turning it anti-clockwise.
3. Lay a few crumpled sheets of paper on the hearth and then a few small sticks, kindling or an approved firelighter.
4. Ignite and close the door.
5. **Never use inflammable liquid i.e. gasoline, petrol paraffin etc. to start or “freshen up” a fire in this heater.**
6. When the fire is well established add fuel to the firebox and adjust the spin valve to the required setting.

## DE-ASHING

Never allow ashpan to over fill as it will cause damage to firebars.

Open the fire door (Part No.21) and remove ashpan (Part No.12) using the operating tool (Part No.34). Close the fire door (Part No. 21). When the ash is disposed of, replace the empty ashpan. (See Fig.11)

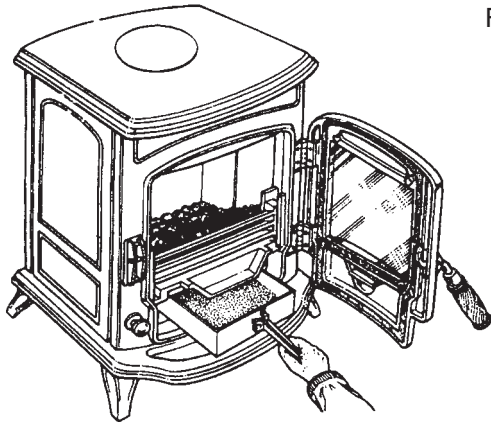

Fig.11

## DISPOSAL OF ASH

Ashes should be placed in a metal container with a tight fitting lid. The closed container of ashes should be on a non-combustible floor or on the ground well away from all combustible materials pending final disposal. If the ashes are disposed of by burial in soil or other wise locally dispersed they should be retained in the closed container until all cinders have thoroughly cooled.

## MAINTENANCE

### CREOSOTE: Formation and Need for Removal

When some fuels are burned slowly, they produce tar and other organic vapours, which combine with expelled moisture to form creosote. The creosote vapours condense in the relatively cool chimney flue of a slow-burning fire. As a result, creosote residue accumulates on the flue lining. When ignited creosote makes an extremely hot fire.

### CHIMNEY CLEANING

Chimney and connector should be cleaned at least twice a year. Once before heating season and once after.

The chimney connector and chimney should be inspected at least monthly during the heating season to determine if a creosote build-up has occurred.

Remove the cast iron baffle plate ( Part No.15) located at the top end of the firebricks (Part No's 13 & 14) before chimney cleaning.

When inspecting a masonry chimney, start at the cleanout door, normally found at the base of the chimney, or on the outside. If your chimney does not have a clean-out door one should be provided.

## REMEMBER COAL GASES ARE TOXIC.

## FIRE SAFETY

To provide reasonable fire safety the following should be give serious consideration:

1. The installation of smoke detectors.
2. A conveniently located class 'A' fire extinguisher to contend with small fires resulting from burning embers.
3. A practical evacuation plan.
4. A plan to deal with a chimney fire as follows:
  - a. Notify the fire department.
  - b. Prepare occupants for immediate evacuation
  - c. Close all openings into the stove.
  - d. While awaiting the fire department watch for ignition to adjacent combustibles from over head stove pipe or from embers or sparks from the chimney.

## GLASS

### 1. How to clean:

The glass will clean itself when there is sufficient heat generated by burning fuel. If a build-up of creosote occurs on the glass it may be due to draft conditions, poor quality fuel or very low burning for a long time. Only clean glass when stove is thoroughly cooled.

Fig.12

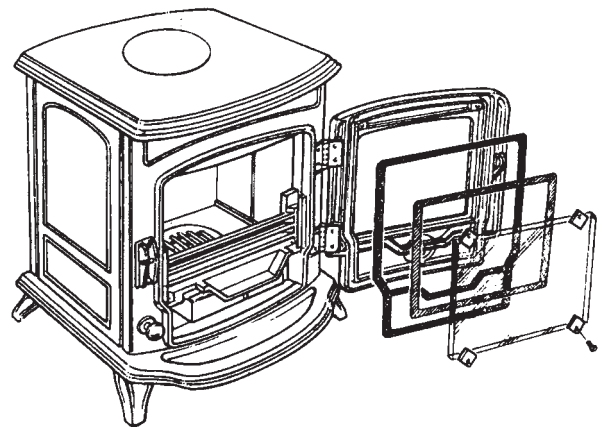

### 2. Glass Replacement: (See Fig.12)

- a. Open the door (Part No.21) fully.
- b. Remove the four corner screws and clips and carefully remove the broken glass.
- c. Clean the glass recess in the door.
- d. Attach adhesive thermal tape to the perimeter of the replacement glass.
- e. Place the thermal tape side of the glass into the door recess and replace the four corner clips.
- f. Tighten screws.
- g. Replace glass only with ceramic glass 5mm thick.

## ENAMEL CLEANING

General cleaning must be carried out when the stove is cool.

If this stove is finished in a high gloss vitreous enamel, to keep the enamel in the best condition observe the following tips:

1. Wipe over daily with a soapy damp cloth, followed by a polish with a clean dry duster.
2. For stubborn deposits a soap impregnated pad can be carefully used on the vitreous enamel.

3. Use only products recommended by the Vitreous Enamel Association, these products carry the vitramel label.



4. **DO NOT USE ABRASIVE PADS OR OVEN CLEANSERS CONTAINING CITRIC ACID ON ENAMELLED SURFACES. ENSURE THAT THE CLEANSER MANUFACTURERS INSTRUCTIONS ARE ADHERED TO.**

## OSCAR SOLID FUEL STOVE EXPLODED VIEW

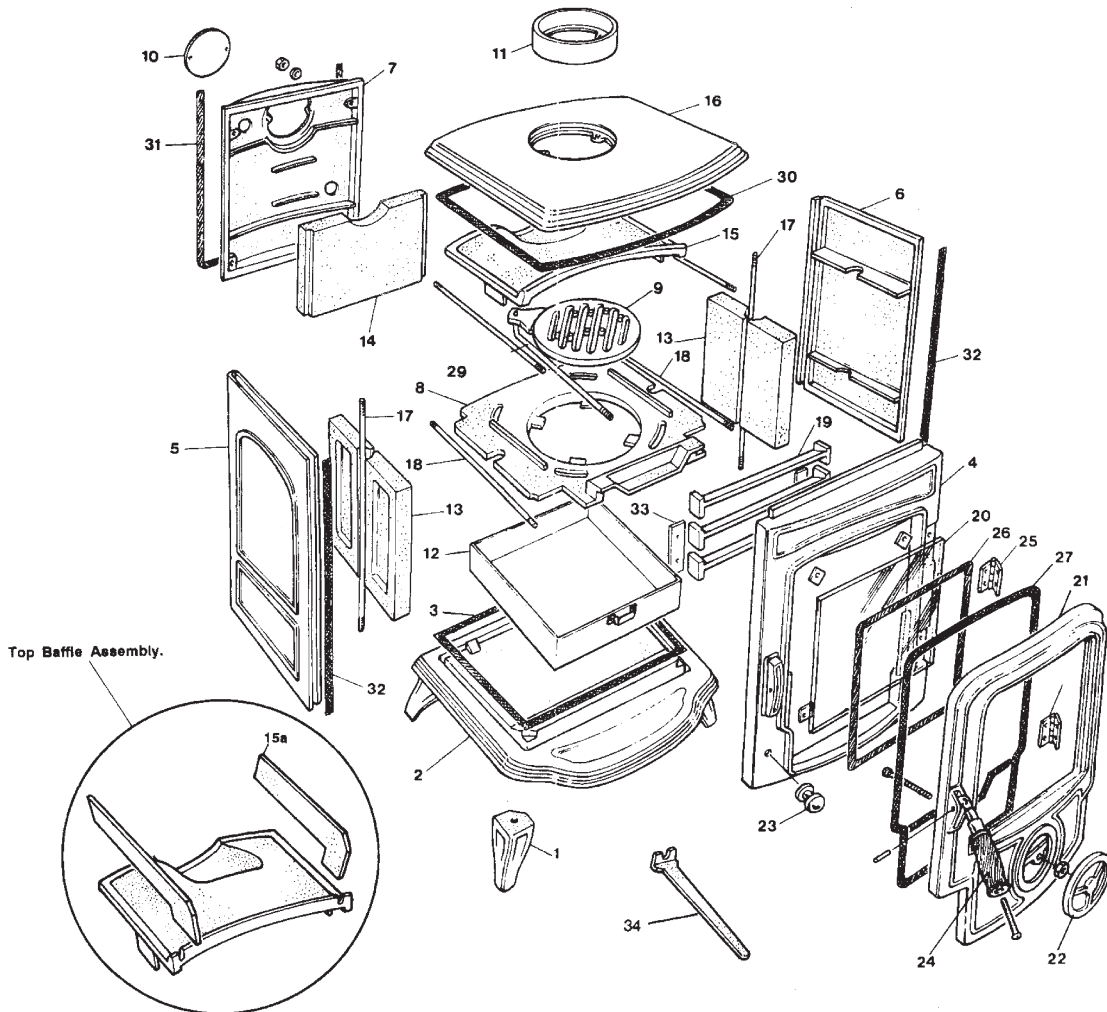

1. Legs	12. Ashpan	22. Spin Valve
2. Base	13. Side Bricks	23. Grate Shaker Control Knob
3. Base Sealing Tape	14. Back Brick	24. Door Handle
4. Front	15. Top Baffle	25. Door Hinges
5. Left Hand Side	15a. Top Protection Baffles	26. Door Glass Sealing Tape
6. Right Hand Side	16. Hob	27. Door Sealing Rope
7. Back Plate	17. Long Tie Bolts	29. Grate Shaker Connecting Rod
8. Grate Base Plate	18. Short Tie Bolts	30. Hob Sealing Rope
9. Grate	19. Fire Fence Bars	31. Back Plate Sealing Rope
10. Blanking Plate	20. Door Glass	32. Side Plate Sealing Rope
11. Flue Spigot	21. Door	33. Fire Fence Retainers
		34. Operating Tool

## INSTALLATION CHECK LIST

### *Flue System*

Tick	<input type="checkbox"/>
------	--------------------------

1. Minimum Flue Height of 4.6 metres (15 feet).
2. Appliance should be connected to a minimum of 1.8 metres (6 feet) of 125mm (5") flue pipe with a horizontal run not exceeding 300mm (12").
3. Appliance should be connected to a chimney of less than 250mm (8") in diameter (otherwise the chimney must be lined with a 5" flue liner).
4. The chimney venting position must be above the main ridge of the roof or adjacent outside obstructions.
5. The chimney serving this appliance should not serve any other appliance.
6. Access should be provided to the chimney serving the appliance to allow for cleaning.

### *Location*

7. Clearance to combustible materials must be adhered to as described in the Clearance to Combustible section.
8. The stove must be installed on a floor protector that covers the area under the stove and extends 18" to the front & 8" to the sides and back.

### *Ventilation & Combustion Air Requirements*

9. The room in which the appliance is located should have an air vent of adequate size to support correct combustion (see Ventilation & Combustion Air Requirement Section for specific details).

---

**Manufactured by  
Waterford Stanley Ltd.,**  
Unit 210, IDA Industrial Estate, Cork Road,  
Waterford, Ireland.  
Tel: (051) 302300 Fax (051) 302315

