

STANLEY

TURNING YOUR HOUSE INTO A HOME

MAEVE

BALANCED FLUE STOVE RANGE

Operation, Installation & Servicing Instructions

IMPORTANT

Please read these instructions carefully and keep them in a safe place.
They will be needed when servicing this appliance.

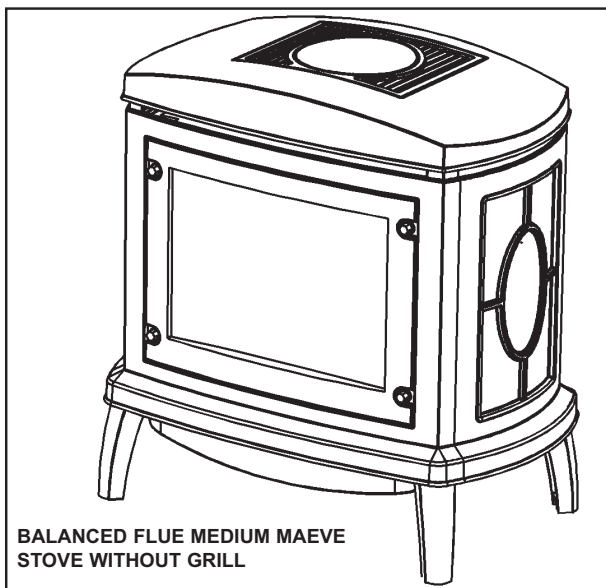

BALANCED FLUE MEDIUM MAEVE
STOVE WITHOUT GRILL

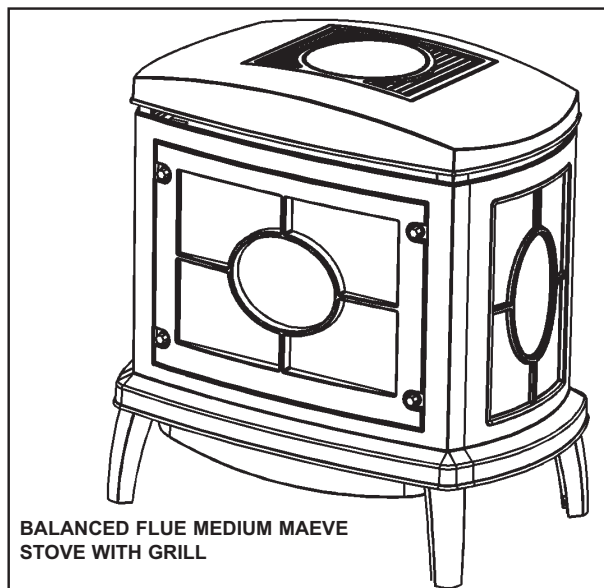

BALANCED FLUE MEDIUM MAEVE
STOVE WITH GRILL

STOVES REQUIRED TO HAVE THE GRILL OPTION MUST BE ORDERED AS THEY ARE FACTORY FITTED.

Country	AT	BE	DK	FI	FR	DE	GR	IS	IE
Natural Gas	*	*	*	*	*	*			*
LPG	*	*	*	*	*	*		*	*
Country	IT	LU	NL	NO	PT	ES	SE	GB	
Natural Gas	*	*	*		*	*	*	*	
LPG	*		*	*	*	*	*	*	

WARNING

Do not attempt to burn rubbish in this stove. This stove must only be operated with the door secured firmly in position. The outer casing of this stove will become hot whilst in operation, it is therefore recommended that the appliance be guarded to protect the young and infirm using a suitable fire guard. Ensure that fabrics such as curtains are not positioned above or near to the stoves outer casing.

Please read these instructions carefully and keep them in a safe place.
They will be needed when servicing the fire.

TECHNICAL SPECIFICATION

GAS CAT.	GAS TYPE	PRESSURE	INPUT	COUNTRY
I ₂ H	G20	20mb	6.25 Gross	AT, DK, ES, FI, GB, IE, IT, PT, SE.
I ₂ L	G25	25mb	5.80 Gross	NL
I ₂ E+	G20 G25	20mb 25mb	5.6 Nett	BE, FR
I ₂ ELL	G20 G25	20mb	6.25 Gross	DE
I ₃ +	G30 G31	29mb 37mb	6.25 Gross	ES, IT, IE GB, PT
			5.6 Nett	BE, FR
I ₃ B/P	G30 G31	29mb	6.25 Gross	DK, FI, NL, NO, SE IS
I ₃ B/P	G30 G31	50mb	6.25 Gross	AT, DE, LU

INJECTOR SIZE	NG	G20 20mb	390
		G25 25mb	530
	LPG	G30 29mb	165
		G30 50mb	150
AERATION SIZE	NG	G20 20mb	Ø 1 x 14.5 mm
		G25 25mb	Ø 1 x 10.0 mm
		G25 20mb	Ø 1 x 12.0 mm
	LPG	G30 29mb	Ø 2 x 14.5mm
		G31 37mb	Ø 1 x 14.5mm
		G30/31 50mb	Ø 1 x 11.0mm
EFFICIENCY CLASS			1
FLUE OUTLET SIZE	INLET		Ø 152mm
	OUTLET		Ø 100mm
INLET CONNECTION SIZE			Ø 8mm
REAR EXIT FLUE	MIN	200mm	
	MAX	550mm	
TOP EXIT FLUE - VERTICAL AND HORIZONTAL			
VERTICAL FLUE HEIGHT FROM TOP OF STOVE	HORIZONTAL LENGTH	RESTRICTOR SIZE	
500mm to 1490mm	250mm to 1000mm	NO RESTRICTOR	
1500mm to 3000mm	250mm to 5000mm	75mm Ø	
TOP EXIT - VERTICAL ONLY INCLUDING OFFSET			
VERTICAL HEIGHT FROM TOP OF STOVE	RESTRICTOR SIZE		
3000mm to 4990mm	52mm Ø		
5000mm to 10,000mm	47mm Ø		

Fig.1

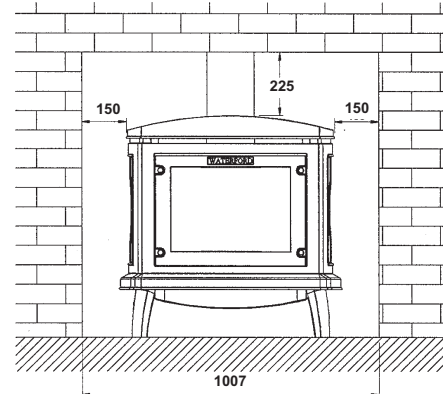

Fig.2

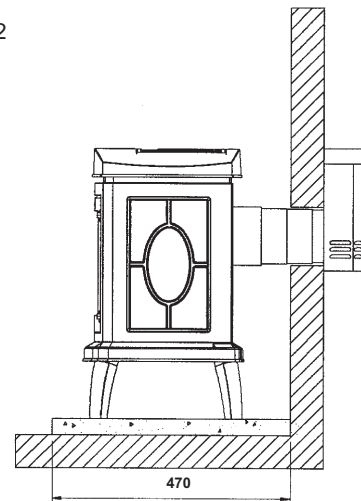

Fig.3

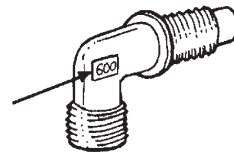

Fig.4



INSTRUCTIONS FOR USE

1. GENERAL

- 1.1 Installation and servicing must only be carried out by a competent person.
- 1.2 In all correspondence, please quote the appliance type and serial number which can be found on the data badge located at the rear of the stove.
- 1.3 Ensure that curtains are not positioned above the stove, and that there is at least a clearance of 300mm between the sides of the stove and any curtains.
- 1.4 **If any cracks are observed in the glass panel, do not use the appliance until the glass has been replaced.**
- 1.5 **If, for any reason, the flue has to be removed from the stove, the seals must be replaced in the inner telescopic section and the inner spigot.**
- 1.6 Do not obstruct the flue terminal in any way i.e. by planting flowers, trees, shrubs etc in the near vicinity, or by leaning objects up against the terminal guard.
- 1.7 Do not use a garden sprinkler so as to allow excessive amounts of water into the flue terminal.
- 1.8 Do not stand or place objects on the terminal guard as this will deform.

2. LIGHTING THE STOVE (See Fig.12)

- 2.1 Ensure the control is pointing to the off position (●).
- 2.2 Depress control knob and rotate anti-clockwise until a click is heard and the knob is pointing at the ignition symbol (*), the pilot should now be lit.
- 2.3 Depress for 5 to 10 seconds and then release, the pilot should remain alight. If the pilot does not light, repeat the above procedure.
- 2.4 If it will not light after repeated attempts, contact the retailer or installer from whom the appliance was purchased.
- 2.5 The appliance may now be turned to the high position to ignite the main burner, then controlled between high and low as desired.

3. TURNING THE STOVE OFF (See Fig.12)

- 3.1 Depress the control knob and turn clockwise until the knob is pointing at the off position (●).

NOTE: THE YELLOW FLAMES WILL APPEAR WHEN THE FIRE HAS GAINED SUFFICIENT HEAT – TYPICALLY 10 TO 20 MINUTES.

IF THE APPLIANCE IS EXTINGUISHED OR GOES OUT IN USE, WAIT 3 MINUTES BEFORE ATTEMPTING TO RE-LIGHT THE APPLIANCE.

4. CLEANING THE STOVE

- 4.1 Remove the four brass nuts retaining the door. Take care when removing the door as it is heavy. See Fig. 24.
- 4.2 Remove all ceramic logs and embers. Store the embers separately as these can not be cleaned.
- 4.3 To clean the logs, use a vacuum cleaner with a soft brush attachment. Ensure all debris is removed from the burner ports.
- 4.4 Replace the ceramics by referring to Section 5.

5. ARRANGEMENT OF FUEL-BED COMPONENTS

The major ceramic components can be found inside the firebox, remove the cast iron door, and remove all the protective packaging from these components.

NOTE: THE CAST IRON DOOR IS HEAVY, TAKE EXTREME CARE WHEN HANDLING TO AVOID DAMAGING THE OUTER CASING.

The fuelbed consists of 5 logs and 1 bag of embers. The logs have letters A, B, C, D and E moulded into them for identification.

- 5.1 Take the rear log A and place it up against the rear of the fire sitting on the two flat ledges of the burner. The two legs of the log should sit between the rear burner ports, see Fig.18.
- 5.2 Place log B on the left hand side of the burner with the location bar on the under side of the log **fully** located in the long slot in the burner. Make sure the log is as far to the left as possible, see Fig.19.
- 5.3 Place log C on the right hand side of the burner with the location bar on the under side of the log **fully** located in the long slot in the burner. Make sure the log is as far to the right as possible, see Fig.20.
- 5.4 Place log D across from the rear log A to log B on the left hand side. There are cutouts in both logs for location.

- 5.5 The half round end of log D should face forwards showing a dark burnt effect, see Fig.21.
- 5.6 Place log E across from the rear log A to log C on the right hand side. Again, there are cutouts for location. Log E should have the small branch on the right hand side when installed correctly. The front of the log should sit on the burner skin and should fit tight to log C, see Fig. 22.
- 5.6 Place the embers along the front of the burner so as to cover the front edge. These can be placed up to the front edge of the burner ports. It does not harm the performance of the stove if these cover the burner ports but less yellow flames will be evident. Place a few embers between logs B and C in the centre of the burner. If any embers remain, keep them in the bag for future use, see Fig.23.

NOTE: ENSURE THAT THE LOGS ARE POSITIONED, AS DETAILED ABOVE.

6. THE FLAME FAILURE DEVICE

- 6.1 This is a safety feature incorporated in all Waterford fires which automatically switches off the gas supply if the pilot light goes out and fails to heat the thermocouple.

7. 'RUNNING IN'

- 7.1 The surface coating on your Waterford fire will "burn off" during the first 24 hours of use, producing a harmless and temporary odour. This will disappear after the short period of use. If the odour persists, ask your installer for advice.

8. SERVICING

- 8.1 The fire must be serviced every 12 months by a qualified Gas Engineer. In all correspondence, always quote the appliance type and the serial number, which may be found on the data badge.

9. ENAMEL CLEANING

General cleaning must be carried out when the stove is cool.

If this stove is finished in a high gloss vitreous enamel, to keep the enamel in the best condition observe the following tips:

- 9.1 Wipe over daily with a soapy damp cloth, followed by a polish with a clean dry duster.

- 9.2 For stubborn deposits a soap impregnated pad can be carefully used on the vitreous enamel.
- 9.3 Use only products recommended by the Vitreous Enamel Association, these products carry the vitramel label.



- 9.4 **DO NOT USE ABRASIVE PADS OR OVEN CLEANSERS CONTAINING CITRIC ACID ON ENAMELLED SURFACES. ENSURE THAT THE CLEANSER MANUFACTURERS INSTRUCTIONS ARE ADHERED TO.**

INSTRUCTIONS FOR INSTALLATION AND SERVICING

IMPORTANT: ENSURE THAT THE APPLIANCE IS CORRECTLY ADJUSTED FOR THE GAS TYPE AND CATEGORY APPLICABLE IN THE COUNTRY OF USE. REFER TO DATA BADGE AND TECHNICAL SPECIFICATIONS AT THE FRONT OF THE BOOKLET. FOR DETAILS OF CHANGING BETWEEN GAS TYPES, REFER TO SECTION 26.

10. SAFETY PRECAUTIONS

- 10.1 This appliance must be installed in accordance with the rules in force, and used only in a sufficiently ventilated space. Please read these instructions before installation and use of this appliance.
- 10.2 These instructions must be left intact with the user.
- 10.3 Do not attempt to burn rubbish on this appliance.
- 10.4 In your own interest, and those of safety, this appliance must be installed by competent persons in accordance with local and national codes of practice. Failure to install the appliance correctly could lead to prosecution.
- 10.5 Keep all plastic bags away from young children.
- 10.6 Do not place any object on or near to the stove. Allow adequate clearance above the stove. (see Figs 1,2,7,8 & 9)

NOTE: IF THE APPLIANCE IS EXTINGUISHED OR GOES OUT IN USE, WAIT 3 MINUTES BEFORE ATTEMPTING TO RE-LIGHT THE APPLIANCE.

11. FLUE REQUIREMENTS

NOTE: THIS APPLIANCE CAN ONLY BE INSTALLED IN CONJUNCTION WITH THE FLUE SUPPLIED.

- 11.1 The flue terminal must be sited in accordance with BS5440: Part 1 (latest edition), see Fig.5 and Table.

NOTE: WHEN INSTALLING THE FLUE, MAKE SURE THERE ARE NO OBSTRUCTIONS AROUND THE TERMINAL SUCH AS SHRUBS, FLOWERS, TREES ETC.

- 11.2 Any terminal which is less than 2 metres above any access (level ground, balcony

or above a flat roof to which people have access), is to be fitted with the guard supplied, see Fig 6. (supplied with rear exit)

- 11.3 Rear exit flue will accommodate walls between 200mm & 500mm.
- 11.4 All vertical and horizontal flues must be securely fixed and fire precautions followed in accordance with local and national codes of practice.

12. VENTILATION & COMBUSTION AIR REQUIREMENTS

- 12.1 The appliance requires no additional ventilation.

13. INSTALLATION OF THE GAS SUPPLY

- 13.1 Before installation, ensure that the local distribution conditions (identification of the type of gas and pressure) and the adjustment of the appliance are compatible.
- 13.2 Ensure that the gas supply is capable of delivering the required amount of gas, and is in accordance with the rules in force.
- 13.3 Soft copper tubing and soft soldered joints can be used but must not be closer than 50mm (2") to the underside of the firebox.
- 13.4 A means of isolating the gas supply to the appliance must be provided independent of any appliance control.
- 13.5 All supply gas pipes must be purged of any debris that may have entered, prior to connection to the appliance.

14. APPLIANCE LOCATION

- 14.1 This appliance must stand on a non-combustible hearth that is at least 12mm thick; the minimum dimensions are shown in Fig.7.
- 14.2 This appliance must be installed on an external wall See Fig. 11.
- 14.3 This stove is not suitable for installation onto a combustible wall; all combustible materials must be removed from the area behind the stove.
- 14.4 Ensure that all clearances to combustible materials are complied with, in particular, there must be 50mm clearance to any rear wall and 150mm either side of the stove. If there is any combustible materials directly above the unit, a minimum distance of 225mm must be maintained. See Fig 8 & 9.

TIMBER FRAMED BUILDINGS

- 14.5 It will be necessary to provide additional clearance when the fire passes through a wall containing any combustible materials so as to prevent a fire hazard.
- 14.6 The hole through which the flue will pass, must have a steel sleeve which is positioned so that an air gap of at least 25mm is maintained between the outer surface of the flue, and any part of the sleeve.
- 14.7 For further guidance on the installation of gas appliances in timber framed buildings, contact your local buildings control authority.

NOTE: ATTENTION MUST BE GIVEN TO ALLOWING ADEQUATE CLEARANCE AT THE SIDES AND REAR OF THE STOVE, TO PROVIDE ACCESS FOR SERVICING.

15. INSTALLATION OF THE STOVE

NOTE: THE CAST IRON DOOR IS HEAVY, TAKE EXTREME CARE WHEN HANDLING TO AVOID DAMAGING THE CERAMIC OUTER CASING.

- 15.1 Remove the outer sleeve and associated packaging from the stove. The ceramic logs and embers are located behind the door, remove the cast iron door using the tool provided. Remove the box and place in a safe location. Remove the adjustable flue assembly and terminal guard from the box. Take care not to lose the fixings and aluminium tape.
- 15.2 The appliance is suitable for top or rear flue exit. If a rear flue has been purchased proceed to 15.3. If a top exit is required proceed to 15.9.
- 15.3 Remove the adjustable flue assembly and terminal guard from the box. Take care not to lose the fixings and aluminium tape.
- 15.4 Decide on the final stove position and ensure that all external flue terminal clearances are compiled with, see Fig 5 & 13. Mark the centre line of the appliance on the wall and mark the height from the top of the hearth to the centre of the flue, see Fig 10.

NOTE: TAKE CARE WHEN MARKING OUT FOR THE FLUE AS IT IS DIFFICULT TO MOVE AFTER INSTALLATION.

A 152mm (6") diameter hole is required to install the flue. This can be achieved by either:

- a) Core drill.
- b) Hammer and chisel.

It is advisable to drill small holes around the circumference when using method b). Make good both ends of the hole.

- 15.5 To set the flue length, measure the total wall thickness, A, then add 94mm. This total flue length will give the minimum clearance of 50mm between the rear of the stove and the wall. Set the length of the flue and seal the joint with the aluminium tape supplied, see Fig.11.
- 15.6 From outside, locate the flue assembly into the hole until the terminal is flat against the wall. Ensure the terminal is vertical. **NOTE THE ORIENTATION OF THE TERMINAL**, see Fig.11. Mark the four fixing holes, remove the terminal and drill the holes, insert the rawl plugs supplied.

NOTE: DO NOT FIX THE FLUE AT THIS STAGE.

- 15.7 Position the stove ensuring all appropriate clearances are observed.
- 15.8 Before inserting the flue through the wall, apply a bead of suitable weatherproof sealant (silicone or similar) around the perimeter of the back face of the terminal. B. Feed the flue through the wall ensuring it travels smoothly. Working from inside, engage the flue in the inner & outer spigots, making sure the rubber seal on the inner and outer spigots are not damaged. From the outside insert the four screws in the flanges of the flue terminal ensuring the sealant has formed a water tight joint to the wall. Finally secure the flue to the spigot by drilling a 3.5mm hole through the larger hole in the spigot and insert the stainless steel screw provided, C see Fig.11.
- 15.9 There are two types of top exit flues available, one with a vertical terminal the other with a horizontal terminal. Minimum and maximum flue lengths are shown in Fig 13. There is an optional decorative collar, part No.8548 to cover the gap between the top plate and the flue.

THIS MUST BE IN PLACE BEFORE THE FLUE IS INSTALLED.

IMPORTANT: WHEN INSTALLING A TOP EXIT FLUE REFER TO THE TECHNICAL SPECIFICATIONS ON PAGE 1 FOR THE APPROPRIATE SIZE RESTRICTOR.

- 15.10 The appliance is factory set for rear exit therefore for top exit the spigots and blanking plates must be reversed, see Fig 14. Take care not to drop or damage the gaskets. If a restrictor is required fit this between the small outlet spigot and the airduct, see Fig14. The large outer spigot must be fitted with the flue fixing hole facing forward.
- 15.11 If the horizontal terminal is used assemble the required amount of vertical flue including the 90° elbow onto the stove. Drill through the fixing hole in the spigot using a 3.5mm drill and secure with the screw provided. Do not forget the optional decorative collar if you have purchased one. A wall plate is supplied to secure the flue to the inside wall. Bend the tab to 90° and loosely place on the elbow.
- 15.12 To determine the height of the hole for the horizontal flue, measure from the hearth to the centre of the elbow, see Fig.10. Refer to 15.4 for methods of cutting the hole.
- 15.13 The final length of horizontal flue pipe incorporates the terminal. This is the only section that can be shortened.

DO NOT ATTEMPT TO SHORTEN ANY OTHER SECTION OF FLUE PIPE.

Refer to sections 15.7 to position the stove.

The fixing holes for the wall plate can be marked on the wall. Use the wall plate as a template. The securing tab can be either on top or underneath the flue. See Fig. 16.

- 15.14. To determine the length of the terminal flue section measure from the outside of the wall to the stop on the 90° elbow. Horizontal flue sections may be fitted between the elbow and the terminal section. see Fig. 16.
- 15.15 Once the length of the terminal has been obtained, mark the flue all the way round, insert the cardboard fitment as shown in Fig. 17. This will support the inner flue. When cutting, take care not to damage the edges of the flue. File any sharp edges from the cut end of the flue, and remove any of the cardboard fitment remaining.
- 15.16 Remove the stove and flue assembly from the hearth and drill the four fixing holes for the wall plate, insert the rawl plugs supplied. Assemble the horizontal flue onto the elbow and reposition the stove ensur-

ing the flue slides smoothly through the wall. Alternatively, place the flue terminal in the wall, place the stove on the hearth and connect the flue to the elbow. Reposition the stove.

- 15.17 Fix the wall plate to the wall using the four black screws provided. Drill through the fixing tab of the wall plate using a 3.5mm drill and secure with the screw provided. Make good and weatherproof around the outside of the flue.
- 15.18 If a vertical only flue system has been purchased refer to Fig.13 for minimum and maximum options. The following areas need careful consideration:-
- (a) Terminal positions
 - (b) Flue supports
 - (c) Weatherproofing
 - (d) Fire precautions
- For all of the above, local and national codes of practice must be adhered to.
- 15.19 Having run the gas supply to the stove, PURGE THE SUPPLY PIPE, this is essential to expel any debris that may block the gas controls. Connect the gas supply to the 8mm-compression elbow at the RIGHT HAND rear corner of the stove, see Fig.12.
- 15.20 Connect a suitable pressure gauge to the test point located on the inlet fitting, and turn the gas supply on. Light the appliance and check all gas joints for possible leaks. Turn the appliance to maximum and check that the supply pressure is as stated on the data badge. Turn the gas off and replace the test point screw, turn the gas on and check the test point for leaks.

16. FUELBED ARRANGEMENT

The fuelbed consists of 5 logs and 1 bag of embers. The logs have letters A, B, C, D and E moulded into them for modification.

- 16.1 Take the rear log A and place it up against the rear of the fire sitting on the two flat ledges of the burner. The two legs of the log should sit between the rear burner ports, see Fig. 18.
- 16.2 Place log B on the left hand side of the burner with the location bar on the under side of the log fully located in the long slot in the burner. Make sure the log is as far to the left as possible, see Fig. 19.
- 16.3 Place log C on the right hand side of the burner with the location bar on the under side of the log fully located in the long slot in the burner. Make sure the log is as far to the right as possible, see Fig.20.

- 16.4 Place log D across from the rear log A to log B on the left hand side. There are cutouts in both logs for location. The half round end of log D should face forwards showing a dark burnt effect, see Fig.21.
- 16.5 Place log E across from the rear log A to log C on the right hand side. Again, there are cutouts for location. Log E should have the small branch on the right hand side when installed correctly. The front of the log should sit on the burner skin and should fit tight to log C, see Fig.22.
- 16.6 Place the embers along the front of the burner so as to cover the front edge. These can be placed up to the front edge of the burner ports. It does not harm the performance of the stove if these cover the burner ports but less yellow flames will be evident. Place a few embers between logs B and C in the centre of the burner. If any embers remain, keep them in the bag for future use, see Fig. 23.

NOTE: ENSURE THAT THE LOGS ARE POSITIONED, AS DETAILED ABOVE.

- 16.7 Ensure that the fibreglass seal on the back of the door is intact, locate the door on the four studs and slide back to the firebox see Fig.24. Secure in place using the four brass dome nuts and the tool supplied, do not over tighten the nuts.

IMPORTANT: NEVER OPERATE THE STOVE WHEN THE DOOR IS REMOVED.

- 16.8 Place the cast iron top and blanking plate in position, see Fig. 25.

17. LIGHTING

- 17.1 Full instructions are given in the Users Section.

SERVICING

18. GENERAL

- 18.1 This appliance must be serviced at least once a year by a competent person.
- 18.2 All principal components can be replaced without removing the stove from its installation, although it is essential that the gas supply to the appliance is turned off at the isolation device before proceeding further.
- 18.3 If, for any reason, the flue has to be removed from the stove, the seals must be replaced in the inner telescopic section and the inner spigot.

19. MAIN BURNER

- 19.1 Turn the gas supply off at the isolation device, remove the door and place to one side, carefully remove the ceramic fuelbed components.
- 19.2 Remove the three securing screws, two at the rear and one at the front left hand side, see Fig.26. Raise the left hand side of the burner to clear the bracket, draw the left hand side forward. The burner venturi is engaged over the injector. When removing the burner be sure to clear the injector, this will release the right hand side of the burner. Take care when removing the burner so as not to damage the pilot burner.
- 19.3 To replace the burner, engage the venturi over the injector ensuring the burner sits on top of the fixing bracket. Lower the left hand side of the burner onto the fixing bracket. Push the burner to the right and whilst holding, insert the three fixing screws.

NOTE: BEFORE REPLACING THE BURNER, ENSURE THE SILICONE SEAL AROUND THE INJECTOR IS INTACT.

20. PILOT UNIT

The pilot assembly consists of five components, which can be individually changed, these are:

- 1) Pilot burner bracket.
- 2) Pilot injector.
- 3) Electrode.
- 4) Thermocouple.
- 5) Gasket.

- 20.1 Turn the gas supply off at the isolation device, remove the door and place to one side, carefully remove the ceramic fuelbed components.
- 20.2 Remove the main burner, see Fig.26.
- 20.3 Remove the two fixing screws from the pilot bracket, see Fig. 27. Gently draw the assembly away from the firebox to give access to the nuts and ignition lead.

NOTE: TAKE CARE NOT TO DAMAGE THE GASKET.

- 20.4 To remove the pilot injector, undo the compression nut on the pilot feed pipe and withdraw the injector which will be hooked onto the olive. When replacing an injector always make sure it is hooked onto the olive before inserting it into the pilot burner, see Fig.28.

- 20.5 To remove the electrode, disconnect the ignition lead and undo the retaining nut. The electrode can now be removed, note the orientation of the electrode terminal when reassembling, see Fig. 29.
- 20.6 To remove the thermocouple, undo the retaining nut and withdraw the thermocouple. Undo the thermocouple from the back of the gas valve, see Fig. 30. Reassemble in reverse order, do not over tighten.
- 20.7 To remove the gasket, disconnect all the above components and withdraw the gas ket. If it is damaged, replace with a new item. Always replace the gasket first when reassembling the pilot components.

21. IGNITION LEAD AND PIEZO

Due to the method of manufacture, these components can only be replaced as an integral unit.

- 21.1 Turn the gas supply off at the isolation device. Pull the control knob off the gas valve spindle to reveal the piezo securing screw access holes. Using a small pozidriv screwdriver, remove the two screws, see Fig. 31.
- 21.2 Pull the piezo body down and remove from the valve, disconnect the ignition lead from the electrode, see section 20.
- 21.3 Replace the assembly with a new unit, refit the screws and connect the ignition lead to the electrode. Check the operation of the new piezo, turn the gas supply on and with the pilot running, check for leaks, especially where the two halves of the valve join. Replace the control knob.

NOTE: WHILST PERFORMING THE PIEZO REPLACEMENT, YOU WILL BE BREAKING THE SEAL BETWEEN THE TOP AND BOTTOM HALVES OF THE VALVE. ENSURE THAT THIS JOINT IS CORRECTLY SECURED AND LEAK TESTED.

22. GAS FILTER

The gas filter is located just inside the inlet boss of the control valve, to replace the filter, proceed as follows:

- 22.1 Turn the gas supply off at the isolation device. Undo the inlet compression nut and pull the pipe clear of the valve, see Fig.33. Prise the small retaining ring out of the inlet and remove the filter.

- 22.2 Replace with a new filter and push into position ensuring that it sits on the shoulder, replace the retaining ring and push into position.
- 22.3 Replace the inlet pipe, turn the gas supply on and check for leaks.

23. MAGNETIC SAFETY VALVE

- 23.1 Turn the gas supply off at the isolation device. Undo the thermocouple connection from the back of the gas valve.
- 23.2 Undo the mag valve retaining nut at the back of the control valve, gently tap out the mag valve and replace with a new unit. Replace the retaining nut and tighten, see Fig.33.
- 23.3 Secure the thermocouple in the rear of the gas control. (Do not overtighten). Turn the gas supply on and check the entire pipework and valve joints for any leaks.

24. MAIN INJECTOR

- 24.1 Turn the gas supply off at the isolation device. Refer to section 19 to remove the main burner.
- 24.2 Undo the compression nut from the feed pipe at the gas control under the appliance. For access, remove the control cover by removing the bolt at the rear of the cover.
- 24.3 Working from inside the firebox, remove the lock nut from the injector, and withdraw the injector complete with the feed pipe from under the appliance.
- 24.4 Holding the injector with a spanner, undo the feed pipe.

NOTE: THE ORIENTATION OF THE INJECTOR.

- 24.5 Reassemble in reverse order, turn on the gas supply and check for any leaks.

25. PRIMARY AERATION PLATE

- 25.1 Turn the gas supply off at the isolation device.
- 25.2 Refer to section 19 to remove the main burner.
- 25.3 Remove the screw retaining the aeration plate (if fitted) from the end of the venturi, see Fig.34.
- 25.4 Reassemble in reverse order with the correct aeration plate.

NOTE: EVEN IF NO AERATION PLATE IS REQUIRED, THE SMALL SCREW MUST BE REPLACED.

26. CHANGING BETWEEN GAS TYPES

In order to change between gas types, it will be necessary to change the following items:

- a. Pilot Injector
- b. Control Valve
- c. Main Injector
- d. Main Burner
- e. Aeration Plate (if required)
- f. Data Badge

The relevant parts can be ordered from the parts list, always quote the appliance type and serial number when ordering spare parts.

NOTE: THE CONTROL VALVE IS FACTORY PRESET FOR THE CORRECT GAS TYPE AND MODEL, A NEW UNIT WILL NEED TO BE ORDERED WHEN CHANGING BETWEEN GAS TYPES.

27. SHORT SPARES LIST

Component	NG			LPG		
	G20 20mb	G25 25mb	G25 20mb	G30 29mb	G31 37mb	G30/31 50mb
Main Injector	IN0028	IN0028	IN0029	IN0030	IN003	IN003
Aeration Plate		ME1348	ME1350			ME1349
Pilot Injector	PI0026			PI0015		PI0027
Burner Assy	GZ1628			GZ1629		
Thermocouple	PI0010					
Mag Unit	GC0079					
Electrode	PI0053					
Gasket	PI0052					
Gas Valve	GC0077					
Gas Filter	GC0065					
Piezo & Ignition Lead	GC0062					
Log A	CE0262					
Log B	CE0263					
Log C	CE0264					
Log D	CE0265					
Log E	CE0266					
Embers	CE0267					

FAULT	CAUSE	POSSIBLE REMEDY
Pilot will not light	Various	Refer to Ignition Functional Check 1
No Spark	Various	Refer to Ignition Functional Check 2
Pilot will not stay lit or goes out in use	Various	Refer to Flame Failure Check 3-
Stove goes out while warming or in operation	Flue blocked Flue not connected at rear of stove	Check terminal for debris. To be checked by an engineer.
Uneven flame pattern	Ceramics not positioned correctly Debris in Burner	Refer to Section 5 or 16. Clean burner ports, refer to Users Manual for guidance.
Blue Flame	Warming Up Aeration plate Insufficient gas pressure	Stove will burn blue until running temperature has been achieved - typically 20 minutes. Ensure that the aeration plate is tight and sits flat. Check the gas pressure and correct if necessary.
Low flame height	Blockage in supply pipe Blocked gas filter Insufficient gas pressure Empty supply tank or cylinder	Disconnect pipe and purge, ensure no debris has entered the stove pipework. Replace filter - refer to Section 22 Check the gas pressure and correct if necessary. LPG only - ensure adequate supply of gas in cylinders.
Short pilot flame length (see diagram 35)	Insufficient gas pressure Blocked pilot injector	Check the gas pressure and correct if necessary. Replace Unit - refer to Section 20.

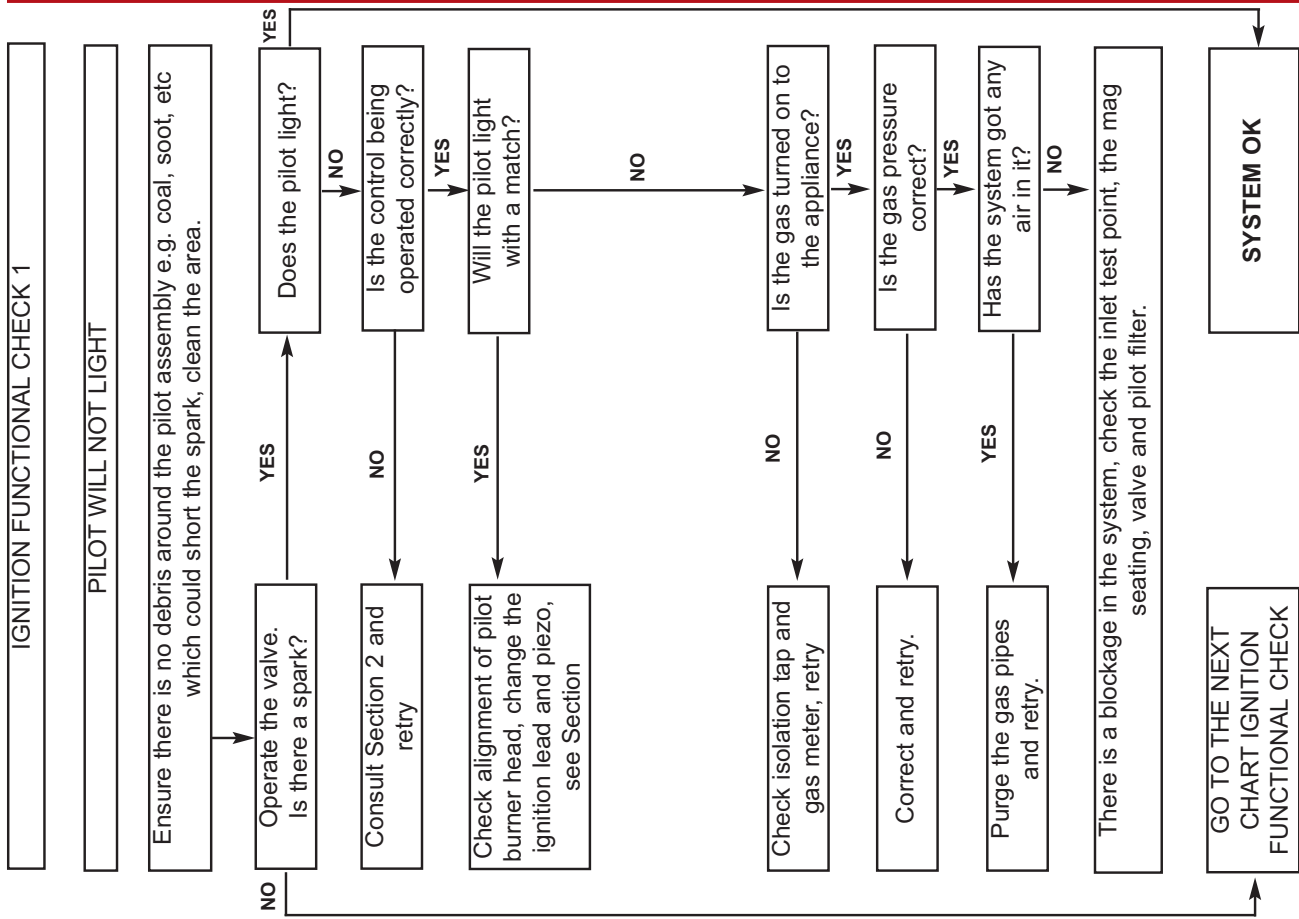

IGNITION FUNCTIONAL CHECK 2

NO SPARK

Ensure there is no debris around the pilot assembly e.g. coal, soot, etc which could short the spark, clean the area.

From Ignition Functional Check

Operate the valve to light the pilot, does the valve 'click'?

YES → Is the valve being operated correctly?

NO → Consult Section 2, retry.

Is pilot burner horizontal? See diagram 33

YES → Reset the pilot burner

NO → Correct and retry.

Has ignition lead become detached or is connection poor?

YES → Check for defective or damaged control knob spindle or cam operation. Check for correct location of piezo components. Correct.

NO → Remove the electrode lead from electrode with insulated pliers hold the tip 4mm from the pilot pipework, is there a spark when the valve 'clicks'?

Is the electrode wire detachable from piezo in the valve?

YES → Remove the electrode lead from the piezo. Operate the valve. Does a spark jump from the piezo to the valve body?

NO → Replace the combined lead and piezo, retry.

Replace the electrode lead and retry

YES → Replace the electrode lead and retry

NO → Replace the piezo and retry.

Replace the piezo and retry.

FLAME FAILURE FUNCTIONAL CHECK 3

PILOT WILL NOT STAY LIT OR FIRE GOES OUT IN USE

Ensure there is no debris around the pilot assembly, e.g. coal, soot, etc which could short the spark, clean the area.

Light the pilot and keep the control knob pushed in at least 10 seconds before letting go.

With the pilot running is the gas pressure as stated on the data badge?

YES → Is the pilot flame of the correct length? See Diagram 35

NO → Change the pilot unit

Will pilot stay alight?

NO → Problem is with the pipework or fittings which lead to the fire. Correct and retry.

YES → With the fire running on full is the gas at the pressure started on the data badge?

Is thermocouple connection good in back of valve?

NO → Replace thermocouple

YES → Run for 3 mins, turn off, time interval until mag unit shuts with a click. Is this greater than 7 seconds?

Will pilot stay alight?

NO → Change mag unit

YES → Run for 3 mins, turn off, time interval until mag unit shuts with a click. Is this greater than 7 seconds?

Change mag unit

Tighten the connection and retry.

Run for 3 mins, turn off, time interval until mag unit shuts with a click. Is this greater than 7 seconds?

YES → SYSTEM OK

NO → SYSTEM OK

Fig.5

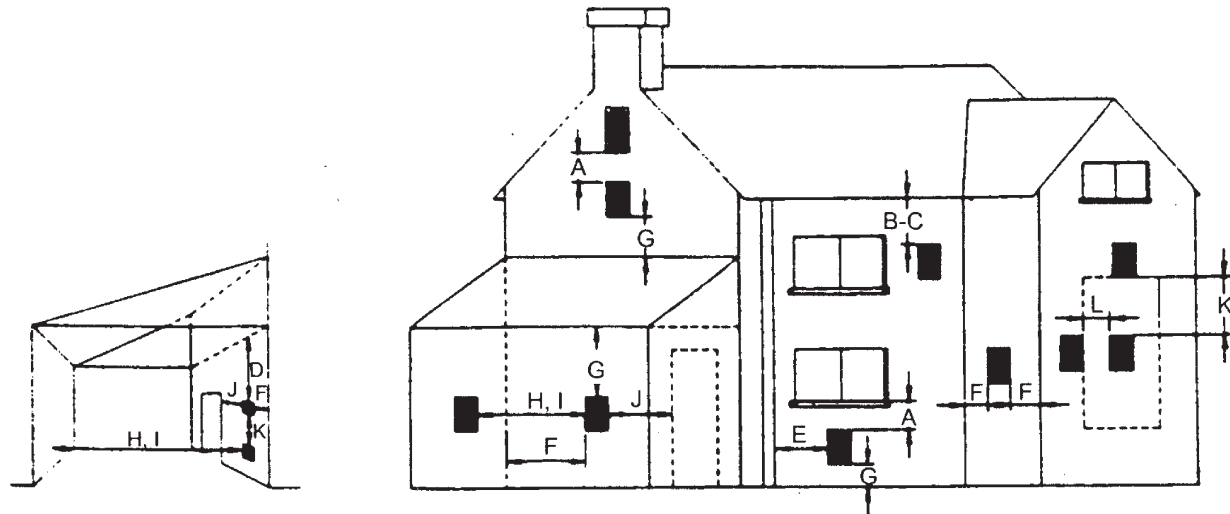

Dimension	Terminal Position	Minimum Distance (mm)
A	Directly below an openable window or other opening e.g. air brick	300
B	Below gutters, soil pipes or drain pipes	300
C	Below eaves	300
D	Below balconies or car port roofs	600
E	From vertical drain pipes and soil pipes	75
F	From internal or external corners	600
G	Above ground, roof or balcony level	300
H	From a surface facing a terminal	600
I	From a terminal discharging towards another terminal	600
J	From an opening in a car port (e.g. door, window)	1200
K	Vertically from a terminal on the same wall	1500
L	Horizontally from a terminal on the same wall	300

Fig.6

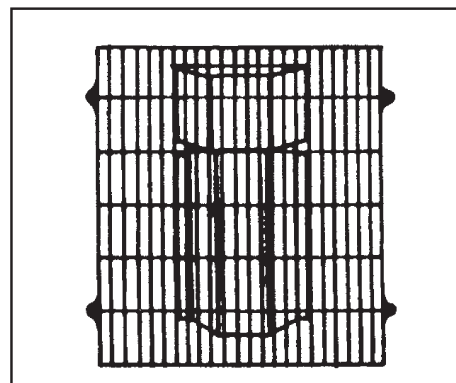

Fig.7

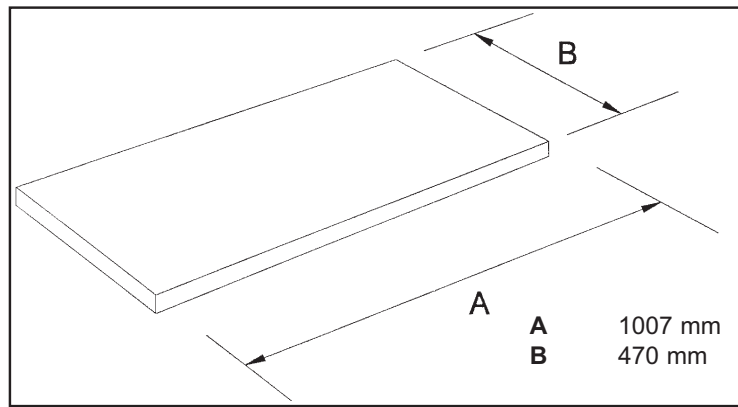

Fig.8

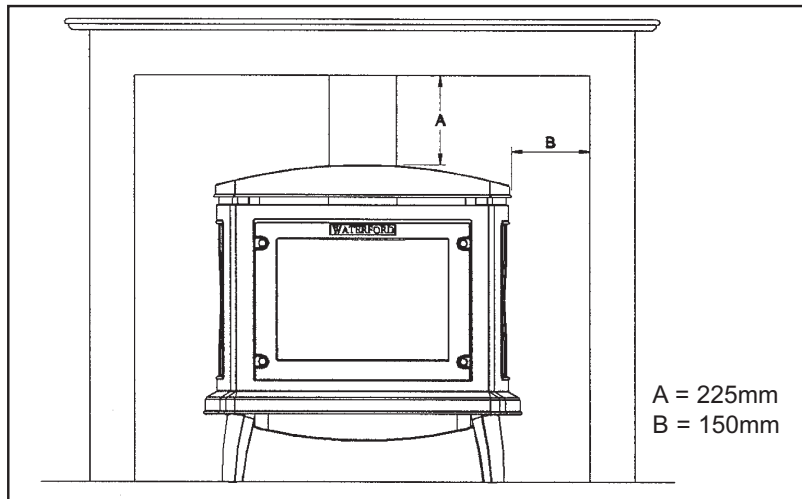

Fig.9

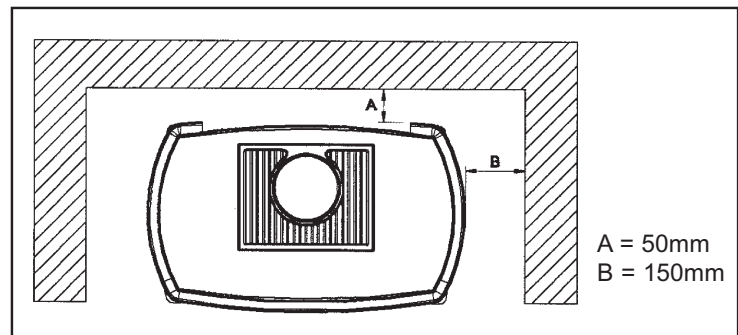

Fig.10

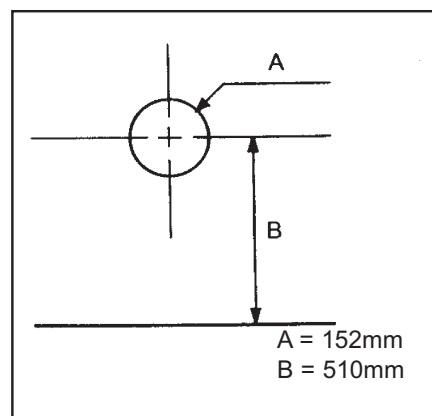

Fig.11

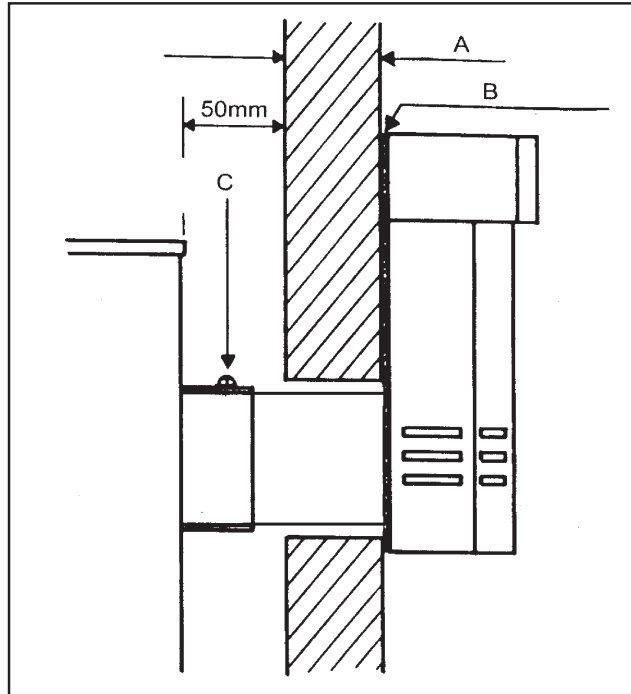

Fig.12

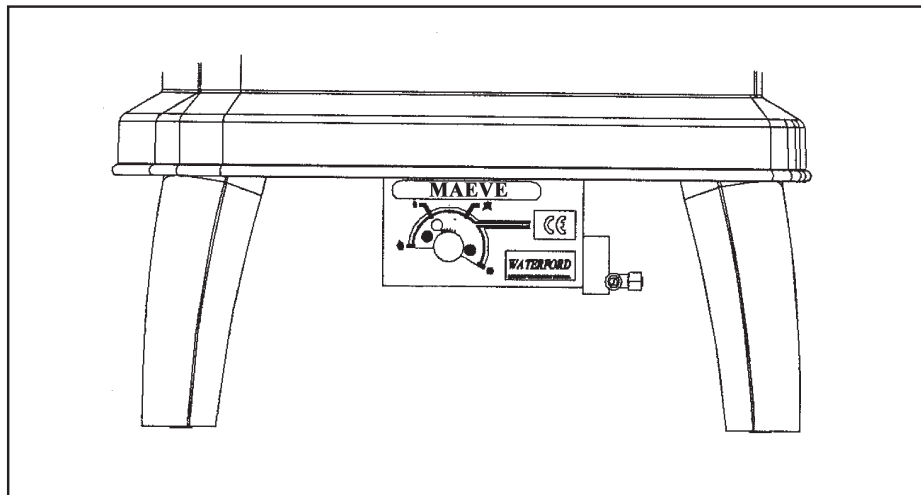

Fig.13

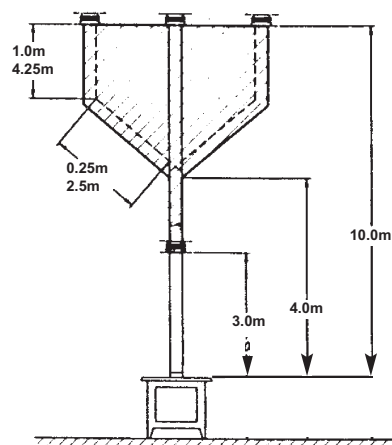
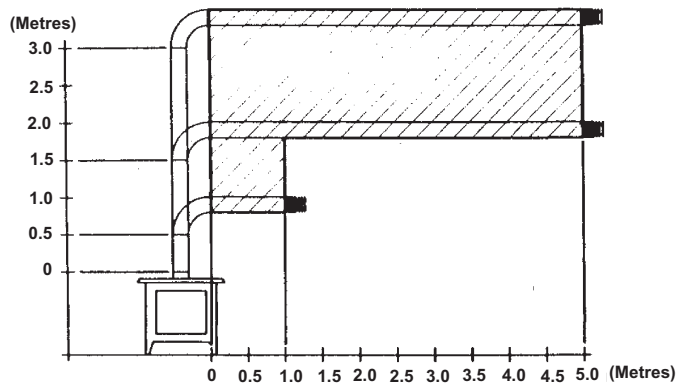

Fig.14

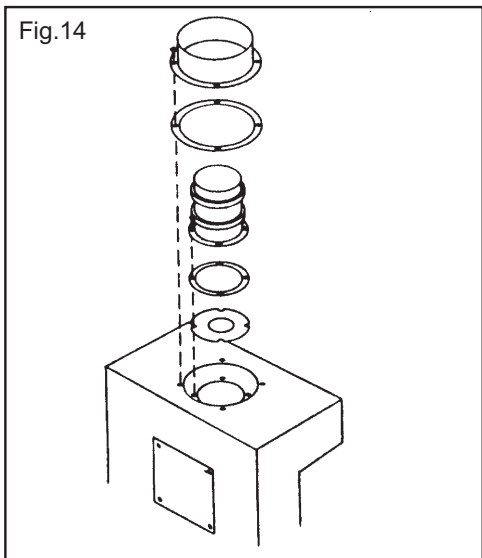

Fig.15

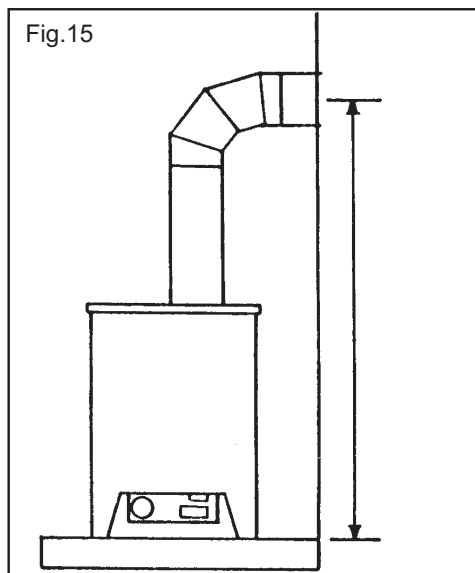

Fig.16

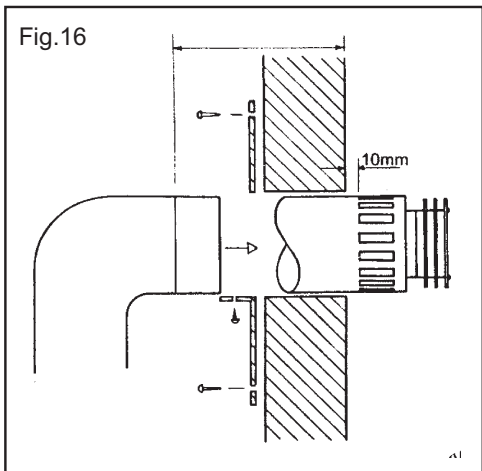
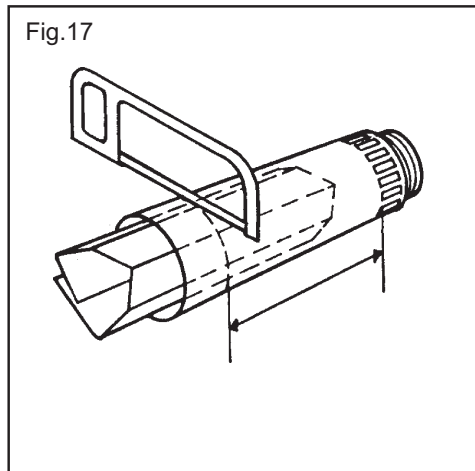

Fig.17



LOG LAYOUT

Note: No log retainer on Balanced Flue Model

Fig.18

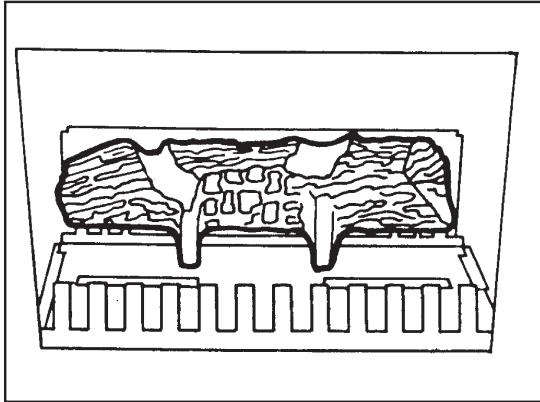

Fig.19

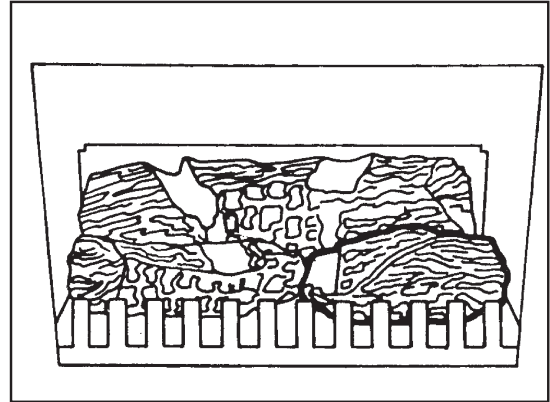

Fig.20

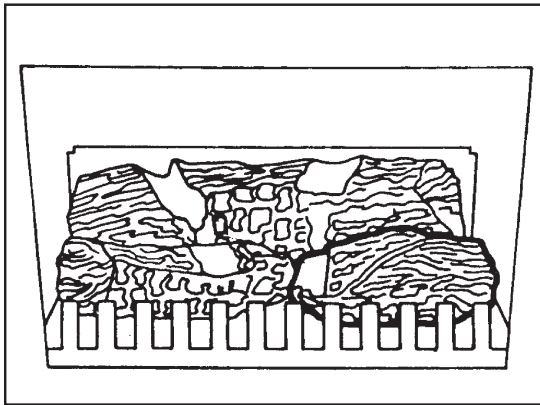

Fig.21

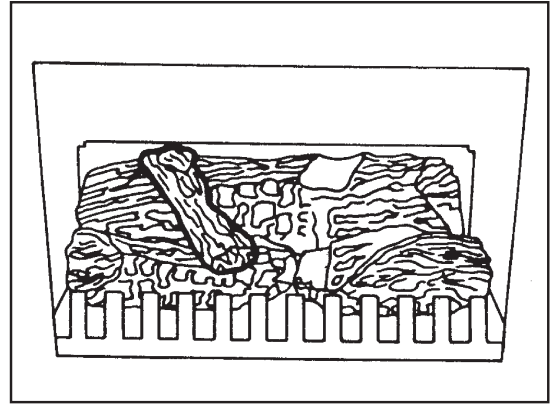

Fig.22

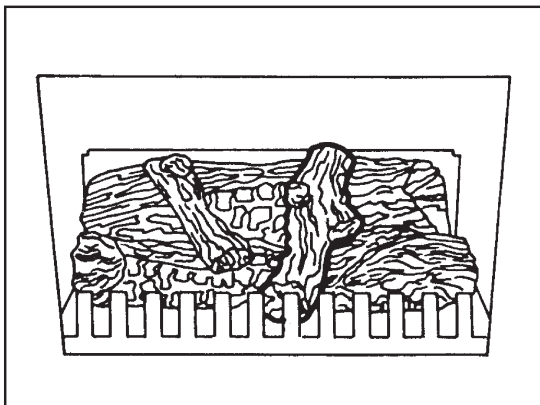

Fig.23

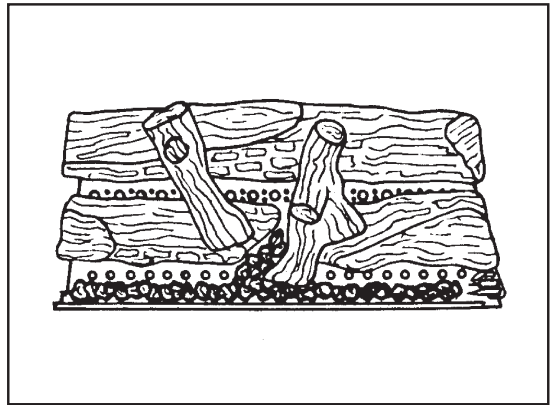

Fig.24

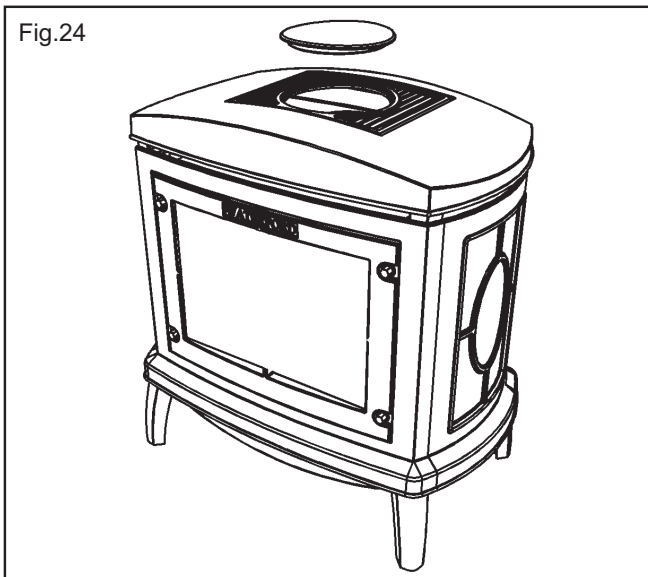

Fig.25

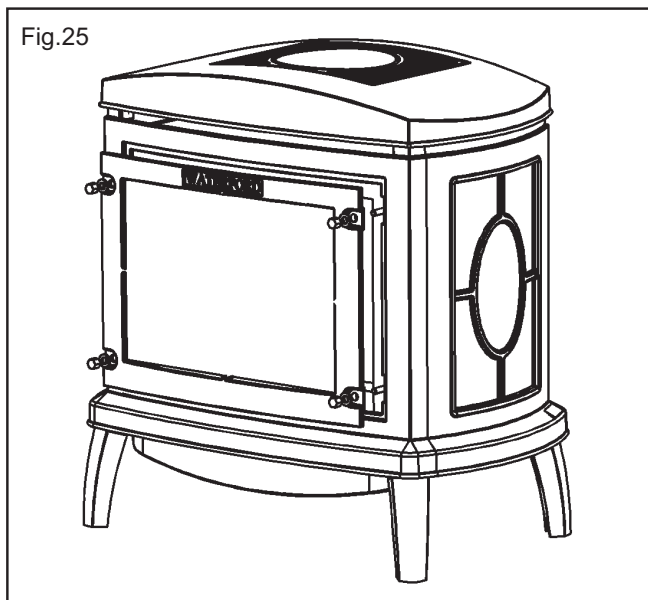
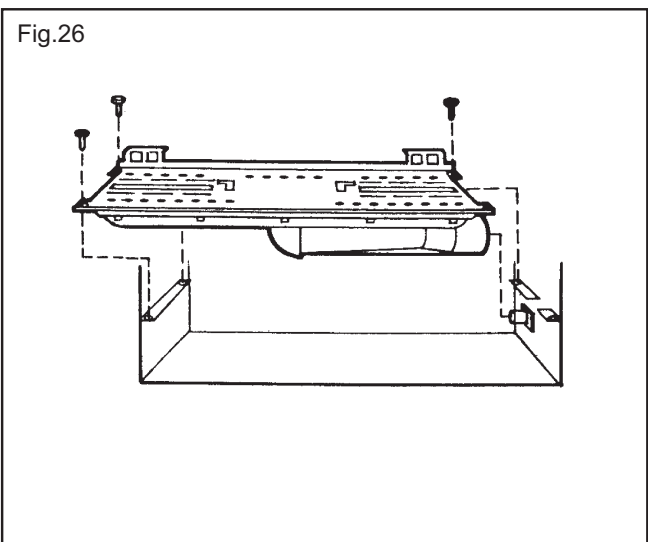
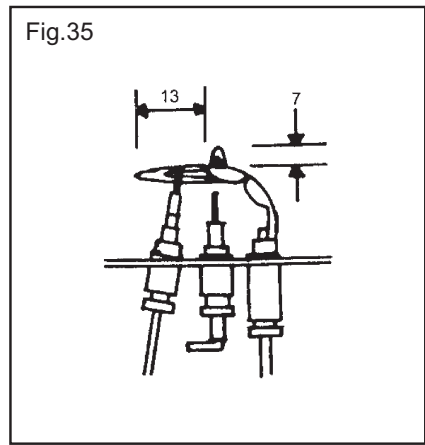
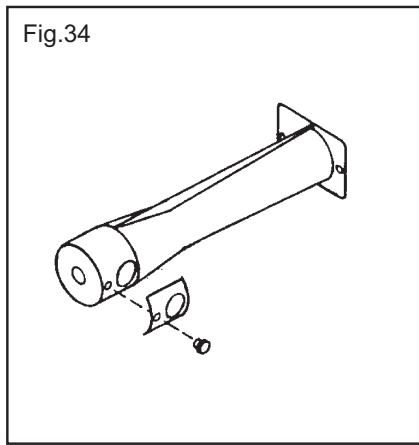
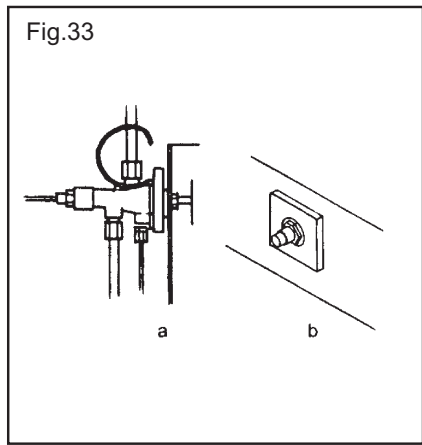
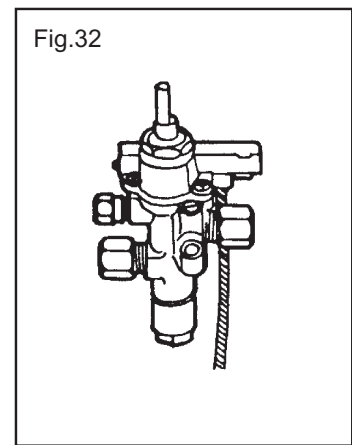
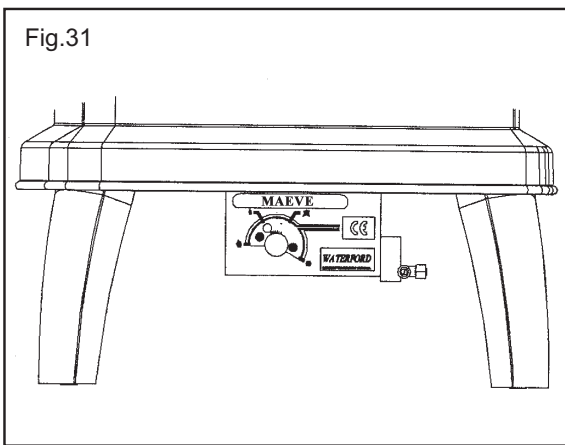
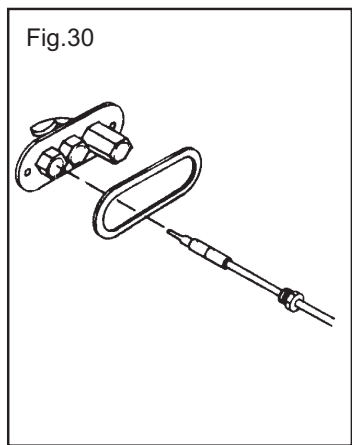
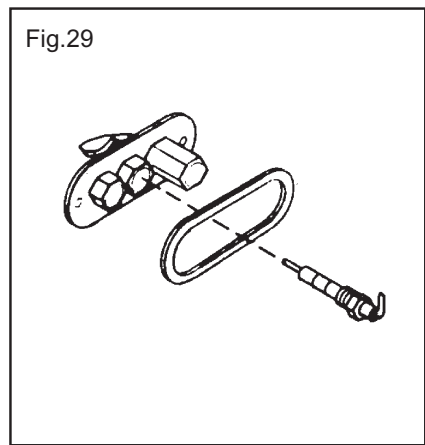
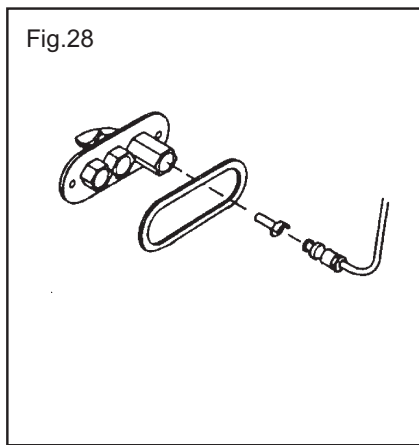
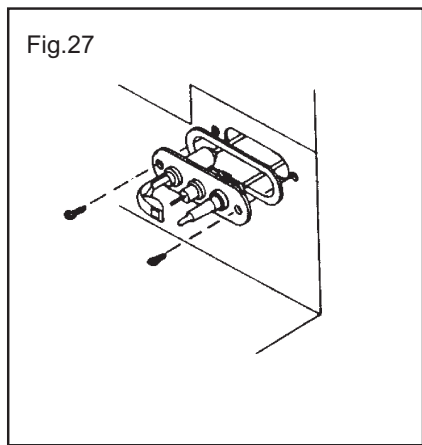

Fig.26





INSTALLATION CHECK LIST

Flue System



1. This appliance can only be installed with the specially designed venting system supplied by Waterford Stanley.

Location

1. Clearance to combustible materials must be adhered to as described in the Clearance to Combustibles section.
2. The stove should be installed as to allow adequate air circulation around the stove and to allow access for installation & servicing.
3. The stove must be installed on a non-combustible insulated floor protector that covers the area of 1007mm x 470mm around and under the stove.

Ventilation & Combustion Air Requirements

1. The room in which the appliance is located should have an air vent of adequate size to support correct combustion, including all other air using devices fitted in the same or adjacent rooms. (see Ventilation & Combustion Air Requirement Section for specific details).

Gas Supply

1. A 8mm rigid gas supply pipe must be used to connect directly from the gas meter to the stove. In the event of a number of appliances using the same supply pipe, the pipe size may need to be increased.
2. A shut off valve must be used to connect the gas supply as close as possible to the stove and should be accessible at all times.
3. A soundness test must be conducted to check all joints for gas tightness.

Manufactured by
Waterford Stanley Ltd.,
Unit 210, IDA Industrial Estate, Cork Road,
Waterford, Ireland.
Tel: (051) 302300 Fax (051) 302315

**STANLEY**
TURNING YOUR HOUSE INTO A HOME