

---

**STANLEY**

**BRANDON  
DRY & DHW GAS MODELS**



***OPERATION INSTRUCTIONS***

*THIS MANUAL IS TO BE LEFT WITH THE END USER*

---

---

# TABLE OF CONTENTS

## PAGE NO.

1.	Introduction . . . . .	2
2.	Technical Data . . . . .	3
3.	Operation . . . . .	4
	Programmable Controller (Mechanical). . . . .	4
	Pre-Operational Checks . . . . .	4
	Time Setting . . . . .	4
	Coarse Adjustment . . . . .	4
	Fine Adjustment . . . . .	4
	Setting the Time Switches. . . . .	5
	Power Failure . . . . .	5
4.	Programmable Controller (Digital). . . . .	5
	To Set Time . . . . .	5
	To Set Alarm . . . . .	5
	To Set Automatic Clock Programme . . . . .	5
	To Change Set Time . . . . .	5
	To Cancel Settings . . . . .	5
	Operating the Appliance . . . . .	6
5.	Ovens . . . . .	6
	The Main Oven . . . . .	6
	The Lower Oven . . . . .	6
	The Hotplate . . . . .	6
	Reset Button/High Limit Stat . . . . .	7
	Burner Control Box Lock-out Reset Button. . . . .	7
	Hot Water Output Reduction (DHW Only). . . . .	7
	Burner Does Not Ignite . . . . .	7
	Hotplate Insulating Covers . . . . .	8
	Cooking Utensils . . . . .	8
6.	Opening Cooker Door . . . . .	8
7.	Cleaning . . . . .	9
	Chimney Cleaning . . . . .	9
	Servicing . . . . .	9
	Mild Steel. . . . .	9
	Ovens . . . . .	9
	Hot Plate . . . . .	9
8.	Cooking Guidance . . . . .	10
	General Information . . . . .	10
	Grilling . . . . .	10
	The Care of your Cooker . . . . .	10
	Cookware . . . . .	10
9.	User Cooking Tips . . . . .	12
10.	Wiring Diagram (Digital Timer). . . . .	13
	Wiring Diagram (Mechanical Timer). . . . .	14
11.	Fault Finding. . . . .	15

---

# INTRODUCTION

To help you make the best use of your cooker, **PLEASE READ THIS BOOKLET CAREFULLY.**

To ensure safety, satisfaction and reliable operation, this quality cooker should be installed and commissioned by a trained and competent person.

Please note for DHW Models the domestic hot water facility involved must fully conform to good plumbing practices, established standards & Regulations.

As manufacturers and suppliers of cooking appliances, we take every possible care to ensure, as reasonably practicable, that these appliances are so designed and constructed as to meet the general safety requirements when properly used and installed.

## United Kingdom

Section 10 of the Consumer Protection Act.  
Gas Safety (Installation and Use) Regulations 1998 (as amended).  
Gas Appliance Safety Regulations (as amended).  
Health & Safety at Work Act.



## Ireland

Safety Health and Welfare at Work Act 1989  
S.I. 101 of 1992 (as amended) & S.I. 150 of 1995 (as amended).

**IMPORTANT NOTICE:** Any alteration to this appliance that is not approved in writing by Waterford Stanley will render the guarantee void. The complete installation must be done in accordance with the current Standards & Local Codes. It should be noted that the requirements and these publications may be superseded during the life of this manual.

### The installation must comply with the following:

The Building Regulations: Part J England & Wales, Part F Section 5 Scotland, Part L Northern Ireland and Part J Ireland.

B.S. 7671: Requirements for Electrical Regulations.

Safety Document 635: The Electricity at Work Regulations.

B.S. 5440: Part 1 & 2: Installations of Flues and Ventilation.

D.M.2. Installation in Timber Framed Buildings.

B.S. 6891 Gas Pipe Sizing.

I.S. 813 Domestic Gas Installations.

### For DHW Models Additionally the Installation must comply with the following:

B.S. 7593: Treatment of water in Domestic Hot Water Systems.

B.S. 7074: Parts 1 & 2: Hot Water Supply.

### Important: Control of Substances Harmful to Health –

It is the Users/Installers responsibility to ensure that the necessary personal protective clothing is worn when handling materials that could be interpreted as being injurious to health and safety.

When handling Firebricks, Fire Cement or Fuels, use disposable gloves.

Exercise caution and use disposable masks and gloves when handling glues and sealants.

When working with fibre glass, mineral wool, insulation materials, ceramic blanket/board, avoid inhalation as it may be harmful if inhaled. Avoid contact with skin, eyes, nose and throat, use disposable protection.

Installation should be carried out in a well ventilated area.

**Cookers can become hot with use and retain their heat for a long period of time after use. Children, aged or infirm persons should be supervised at all times and should not be allowed to touch hot surfaces.** The manufacturers reserve the right to make alterations to design, materials or construction for manufacturing or other reasons subsequent to publication.

## TECHNICAL DATA

FUELS: 2nd Family, Natural Gas or 3rd Family, L.P.G.  
 PRODUCT IDENTIFICATION: 63AT5325  
 COUNTRY OF DESIGNATION: G.B., I.E., B.E., A.T., D.K., E.S., F.I., I.T., P.T., S.E. & F.R.  
 GAS TYPES: N.G.: I<sub>2H</sub>, G20, 20 mbar (I.E., G.B., A.T., D.K., E.S., F.I., I.T., P.T., & S.E.)  
 L.P.G.: I<sub>3P</sub>, G31, 37mbar (I.E., G.B., B.E., F.R., E.S., & P.T.)  
 MAINS CURRENT: 230V - 240V, 50 Hz, A.C.  
 SUPPLY FUSE RATING: 3 A  
 IONISATION CURRENT: Minimum of 7µA  
 I.P. PROTECTION DEGREE: IP 20  
 ELECTRICAL INPUT: 90 watts.

MAINS GAS PRESSURE:  
 MAXIMUM FLUE RESISTANCE:  
 GAS RATES  
 GROSS HEAT INPUT:  
 MANIFOLD PRESSURE -  
 SPACE HEATING -

NATURAL GAS	L.P.G.
20 mbar (8" wg)	37 mbar (14.8" wg)
0.8 mbar (0.32" wg)	0.7mbar (0.28" wg)
1.48m <sup>3</sup> /hr(52.26 ft <sup>3</sup> /hr)	0.59m <sup>3</sup> /hr (20.8 ft <sup>3</sup> /hr)
15.8 kW (53,909 Btu's/hr)	15.8kW(53,909Btu's/hr)
6.4 mbar (2.56" wg)	4.6mbar (1.85" wg)
1.70 kW (5,800 Btu/hr)	1.7kW (5,800Btu's/hr)

COOKER WEIGHT: 356 Kgs 783 lbs  
 MAINS GAS PIPE: Installation of gas pipe to be carried out in accordance with BS 6891.

### ADDITIONAL TECHNICAL DATA FOR DHW MODELS:

MANIFOLD PRESSURE: N.G.: 6.4 mbar (2.56"wg).  
 L.P.G.: 4.1 mbar (1.65" wg).  
 MAX. DHW BOILER WORKING PRESSURE: 28 p.s.i.  
 TEST PRESSURE IN DHW BOILER: 40 p.s.i.  
 OPERATING TEMPERATURE LIMIT IN DHW BOILER: 96°C (194°F)  
 DHW BOILER CAPACITY: 10 Litres (2.2 gallons)  
 DHW BOILER MATERIAL: 3mm Stainless Steel  
 COOKER WEIGHT: 360 kg (790 lbs)  
 DHW BOILER OUTPUT: 3.8 kW (13,000 Btu's) (Continuous Running)

Whilst the primary air and gas rate on this appliance have been set, combustion tests and the gas rating must be undertaken, during commissioning and adjusted accordingly.

**NOTE:** This appliance must be installed in accordance with the regulations in force and only used in a well ventilated location. Read the technical instructions before installing this appliance. Read the user's instructions before lighting this appliance.

# OPERATION

**Note:** The controls are located behind the top left hand door.

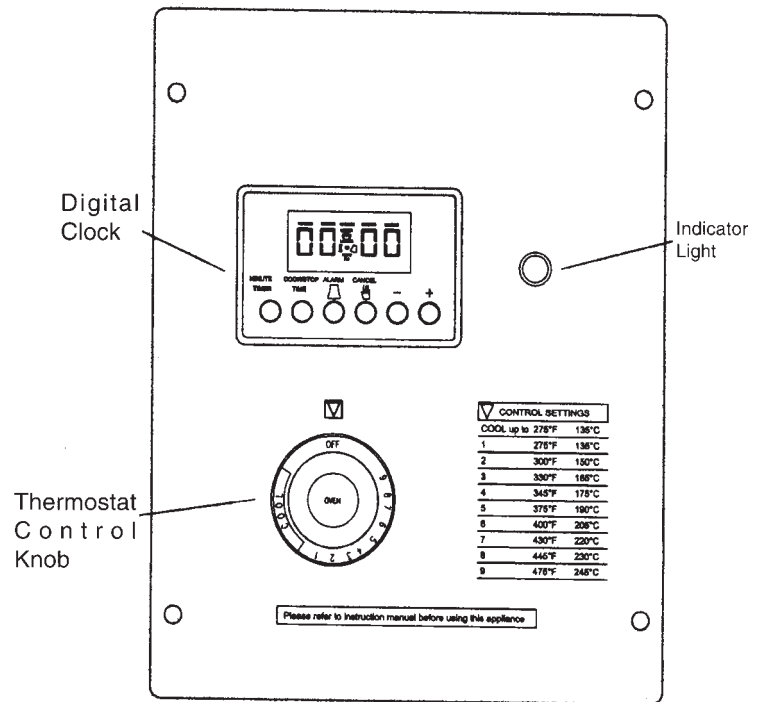
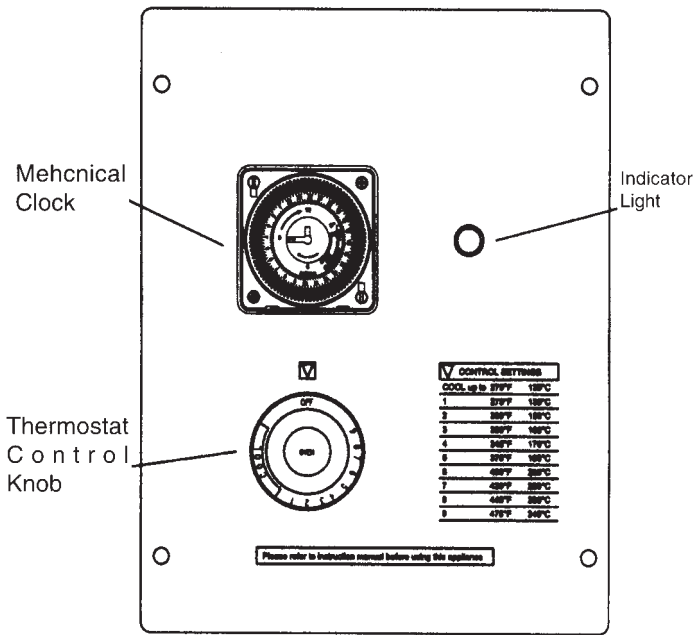

## PROGRAMMABLE CONTROLLER (MECHANICAL)

The programmer controls your cooker which allows you to set your cooking times. It will enable you to pre-set the times when cooking is switched ON and OFF.

## PRE-OPERATIONAL CHECKS

- Check that the cooker is connected to the mains electricity.
- Check that the oil supply line is purged of air and that all valves are open.
- Check that appliance thermostats are in the off position.

## TIME SETTING - For DHW Models Only

### Mechanical Clock Programmable Controller

### COARSE ADJUSTMENT

Rotate switching dial (section containing numbers 1 - 24) in direction of the arrow until the current time is almost opposite the arrow marked F (here: 19.45) Fig.1

Fig.1

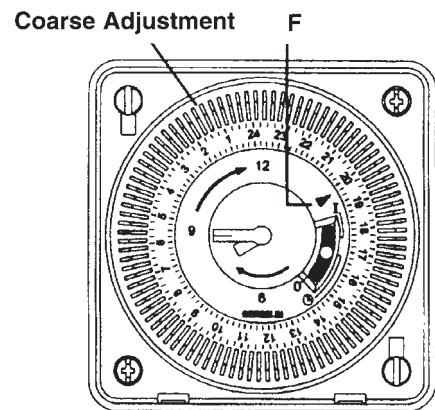

### FINE ADJUSTMENT

Push the minute hand in the direction of the arrow until the current time is opposite the arrow marked F (here: 20.00) Fig.2.

Fig.2

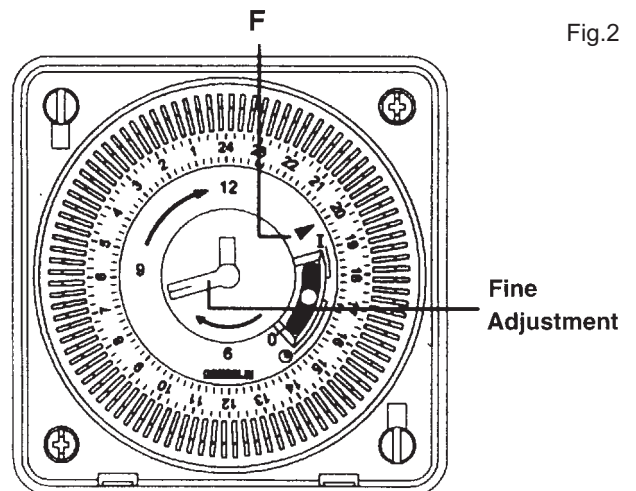

## SETTING THE SWITCHING TIMES

To operate the appliance using the automatic switching set the large slider to position marked On the outer ring there are 96 small sliders, each slider represents a time period of fifteen minutes. The cooker switches "ON" or "OFF" depending on the position of these sliders. When the slider is nearest the centre of the clock it is in the "OFF" mode, and when the slider is moved away from the centre of the clock it is in the "ON" mode.

### Switching example:

ON - Function from 18 - 22 h

OFF - Function from 22 - 18 h

Fig.3

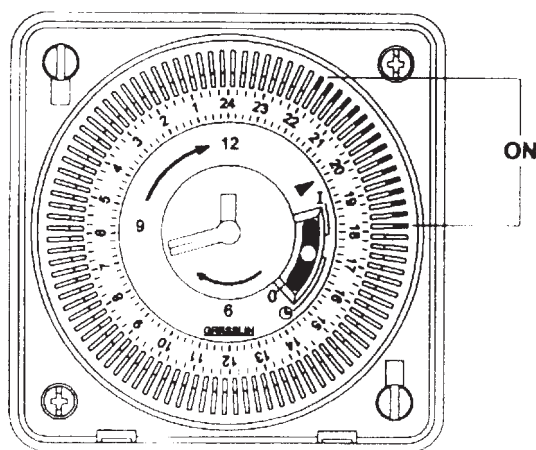

## POWER FAILURE

In the event of power failure, the programmer will need to be reset, but switching times will not be altered. If appliance does not operate normally please refer to Fault Finding.

## TIME SETTING FOR DRY MODELS ONLY

### DIGITAL CLOCK PROGRAMMABLE CONTROLLER

**TO SET TIME (NOTE:** Cooker cannot be operated until the time is set).

1. When Power is applied, display flashes "AUTO" and "0.00" alternatively.
2. Press buttons 1 & 2 from left, "0.00" is displayed steadily. Letters "AUTO" flash.
3. Press plus or minus button until the actual Time - Of - Day is displayed.
4. When releasing the buttons Time - of - Day starts precisely to the second --.--. The cooking pot symbol "☪" is illuminated steadily.

## INTERVAL TIME

**Note:** Interval Time does not control the cooker, it sets off an alarm after the preset period of time.

1. Press interval time button (first button on the left) display shows "0.00" and the bell symbol is displayed
2. Press plus button until the desired setting is displayed.
3. On releasing the button, run down of interval time starts after the 4 - seconds time window. Time - of - Day re-appears in the display with the cooking pot symbol illuminated steadily.
4. The interval time having elapsed. The acoustic signal sounds with two beeps, pause, two beeps etc....

## OPERATION PERIOD

**Note:** When setting the operation period, the programmer automatically sets a stop which is equal to the operation period added to the current time. If you do not want the cooker to start immediately, you will have to adjust the **STOP** time accordingly.

1. Press operation period button (second button from left), display shows "0.00" and the cooking pot symbol is displayed steadily.
2. Press plus button until the desired operation period is displayed.
3. Releasing the button starts the run down of time.
4. The operation period having elapsed, the acoustic signal sounds with four beeps, pause, four beeps etc.. The cooking pot symbol disappears, letters "AUTO" flash until the manual button is pressed. The cooking pot symbol is illuminated steadily.

## STOP

### (Time at which you want cooker to switch off)

1. Press operation stop button (third button from left), display shows "0.00" and the cooking pot symbol is displayed.
2. Press plus button until the desired operation STOP is displayed (Time at which you want oven to switch off).
3. Releasing the buttons start run down of time, Time - Of - Day reappears. Letters "Auto" and the cooking pot symbol is illuminated steadily. Operation Period starts at once.
4. The operation period having elapsed, the acoustic signal sounds with four beeps, pause, four beeps etc.. The cooking pot symbol disappears, letters "AUTO" flash until the

manual button is pressed. Thus switching over to manual mode. The cooking pot symbol is illuminated steadily.

## MANUAL MODE

When programming operation period or operation stop, the timer automatically transfers into automatic mode, being displayed by the letters "AUTO" illuminated. The set programs being completed, letters "AUTO" illuminated. The set programs being completed, letters "AUTO" flash and the time can be switched over to manual mode by pressing the manual button. The cooking pot symbol is illuminated steadily.

## CORRECTING OR CLEARING PROGRAMS

Set programs can be corrected at any time by pressing the respective button and either the plus or minus button depending on whether the program is to be cut short or prolonged.

Clearing is done by setting the program to "0.00". Clearing operation period automatically causes clearing of operation stop and vice-versa. When operation period or operation stop are programmed Time-Of-Day cannot be corrected. The setting of nonsensical programs is impossible (e.g. operation period is programmed and operation stop is set too early).

**NOTE:** In the event of a short term power failure the clock display will disappear and then turn when the power is reinstated. If the power supply is interrupted for a lengthy period of time the clock display will be lost.

## OPERATING THE APPLIANCE

For the appliance to operate both the oven control knob and the timer must be set correctly.

The oven control knob setting corresponds to a temperature. The control setting and their corresponding temperatures are shown on the control panel to the right of the control knob. These temperatures are a guideline to the average temperature in the top oven.

Either time clock can be used to switch automatically as outlined above. The mechanical timer also has "continuous on" and continuous off" mode on the digital time so the appliance must be switched off using the oven control knob.

The indicator light on the control panel is illuminated when the solenoid valve is open. It will take approximately 8 seconds after the cooker is turned on before the solenoid valve is opened.

## OVENS

### THE MAIN OVEN

This oven is your simmering oven, your baking oven and your roasting oven. It is a generous size of 390 x 310 x 406 mm (15 1/4 x 12 1/4 x 16 inches) - big enough to take a large turkey. It is of a cast-iron construction which gives a perfect roast, sealing in all the juices and flavours. The oven is fitted with a thermometer which gives the average temperature in the oven. There are two chromed steel shelves and four shelf positions. The main oven is controlled by the thermostat inside the top left hand door. The top shelf will be a shade hotter than the centre of the oven and the bottom shelf will be a shade cooler, giving you different zones of heat in the main oven - this allows you to cook foods that require different temperatures in the same oven. Lifting the insulating lids on the hotplate and cooking for any length of time, will not affect the oven temperature.

The Stanley has hot flue gases flowing around four faces of the main oven. The all-round heat allows you to cook on the base of the main oven - marvellous for browning and crisping the bases of fruit pies and for finishing off pizzas and quiches. You can also oven fry on the base of the oven using metal or cast-iron cookware, and its ideal for poaching smoked haddock - no more tell-tale cooking smells in the kitchen, as these pass directly into the flue.

### THE LOWER OVEN

The lower oven measures 390 x 220 x 406 mm (15 1/4 x 8 3/4 x 16 inches). It has one chromed shelf with two shelf positions. Like the main oven, it has a cast-iron interior and gives a similarly superb finish to dishes that need more gentle cooking.

The lower oven is heated from its top face as the flue gases pass between the two ovens. The temperature of this oven is approximately half that of the main oven and the top shelf position is hotter than the lower one.

The lower oven really comes into its own when you are cooking a large family meal or having a baking session - any time, in fact, when cooking foods that need different temperatures.

## HOTPLATE

The hotplate in this appliance is treated with a protective coating, which when heated will evaporate and will cause an odour for a short period of time on first lighting.

One of the outstanding features of the Stanley is its hotplate. It is generous in size and is machine ground for maximum heat transfer to your cookware.

The temperature of the hotplate is controlled by the oven control thermostat. During the cold winter months, when you are busy in the kitchen and you want warmth from the cooker and heat in the hotplate, a thermostat setting of 100°C will give you the heat you require. If you need the hotplate to be hotter, turn the thermostat up to a higher setting. The hottest part of the hotplate is at the left side, the centre is a little cooler and the right side cooler still.

The type of cookware you use will affect the hotplate's performance. Good contact between pan and hotplate is essential.

On the right there is a small simmering plate. This is ideal for keeping the coffee-pot warm, or you can keep a kettle of water there ready to move on to the hotplate. All sorts of culinary jobs can be done over this gentle heat - dissolving gelatin, melting fats and chocolate, steaming vegetables, and cooking soups and stocks.

**IMPORTANT: DO NOT ALLOW THE COOKER BURNER TO RUN WITH THE MAIN OVEN DOOR OPEN, OTHER THAN WHEN ATTENDING TO FOOD.**

### RESET BUTTON/HIGH LIMIT STAT

A high limit thermostat is located behind plinth on bottom of cooker. Remove plinth by sliding approx 10mm to the left.

The thermostat button will pop out if the temperature selected is exceeded. To reset simply unscrew the protective cap and press the plastic button inwards. (See Figs 4, 5, & 6) If this situation persists contact your Service Engineer.

Fig.5

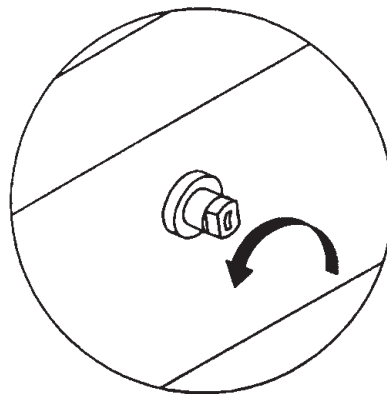
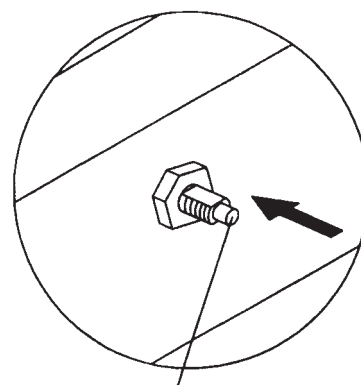

Fig.6



PUSH PLASTIC BUTTON TO RESET

### BURNER CONTROL BOX LOCK-OUT RESET BUTTON

The control box reset button, located on the base underneath the left hand door will illuminate if the burner experiences a problem.

Press the button to reset the control box. If this situation persists, contact your Service Engineer.

(See Fig. 7)

Fig.4

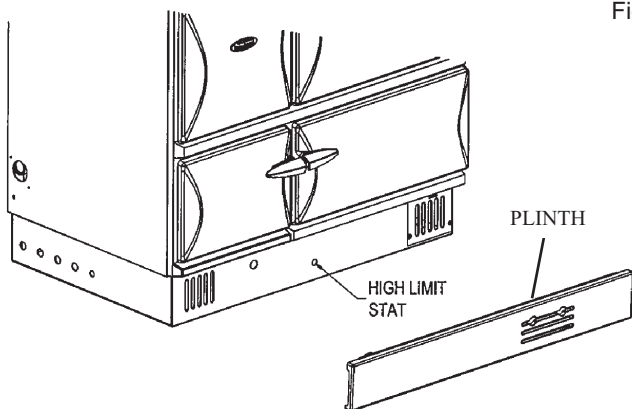
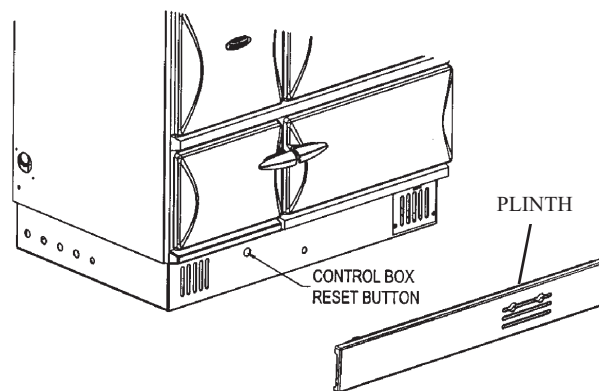

Fig.7



### HOT WATER OUTPUT REDUCTION (DHW ONLY)

The requirement for hot water differs from household to household. If excess hot water is provided the temperature in the boiler will reach its limit temperature and the appliance will shut down

until the limit stat is manually reset. The amount of hot water provided can be reduced by hanging optional boiler insulation panels to the boiler. (See Fig. 8). These are available to order. The panels can be hung individually or together for a further reduction in boiler outputs.

When fitting both panels together, the panel must be fitted to the left hand side first. Both panels are the same size.

Fig.8

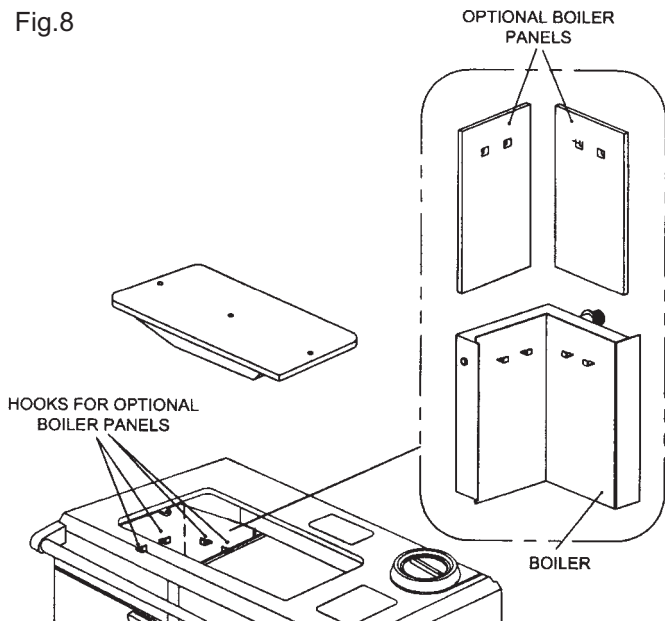

## BURNER DOES NOT IGNITE

### Check:

- that the electricity is switched on.
- that the gas supply valve is open.
- that the thermostat reset button is pressed in.
- that the programmer is on and the thermostat is calling for heat.
- that the "lock out" button on the control box at the base of the cooker is not illuminated.
- If in doubt contact your local Stanley Gas Engineer.

## HOT PLATE INSULATING COVERS

The insulating covers retain most of the heat that would otherwise be radiated into the kitchen. They also retain the heat in the hot plates so that rapid heating of cooking utensils will occur when one or both of them are lifted for cooking purposes.

Fig.9

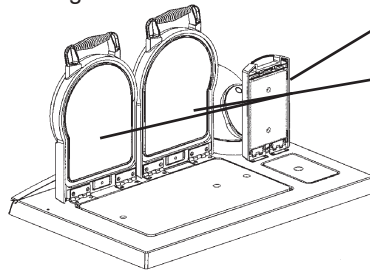
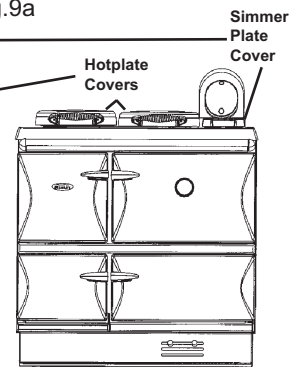

Fig.9a



**IMPORTANT: WHEN HOTPLATE IS NOT IN USE ENSURE THAT HOTPLATE COVERS ARE IN A DOWN POSITION.**

## COOKING UTENSILS

For best cooking results and economy of operation use heavy based, flat bottomed utensils.

**IMPORTANT: DO NOT USE MIS-SHAPED PANS WHICH MAY BE UNSUITABLE. DO NOT USE ROUND BASED WOKS.**

**IMPORTANT: WE DO NOT RECOMMEND DEEP FAT FRYING ON THIS APPLIANCE.**

## OPENING COOKER DOOR

Fig.10

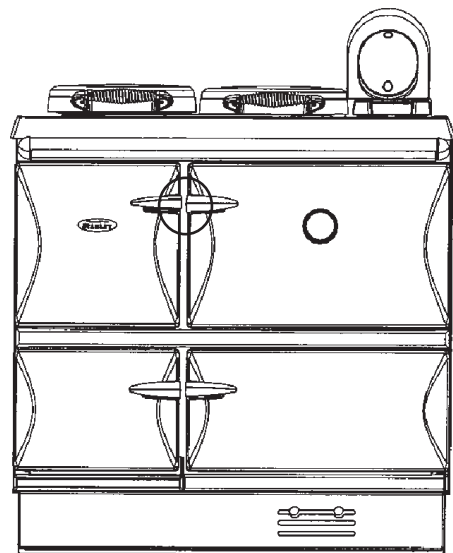

To open the cooker door grip the door handle between the fingers and thumb as per Fig.13, swing the door handle in an outwards and upwards direction as shown in Fig. 14.

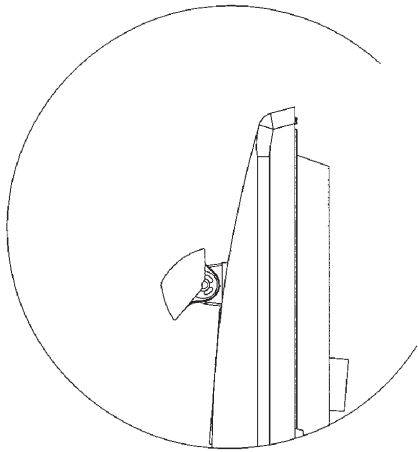

Fig.11

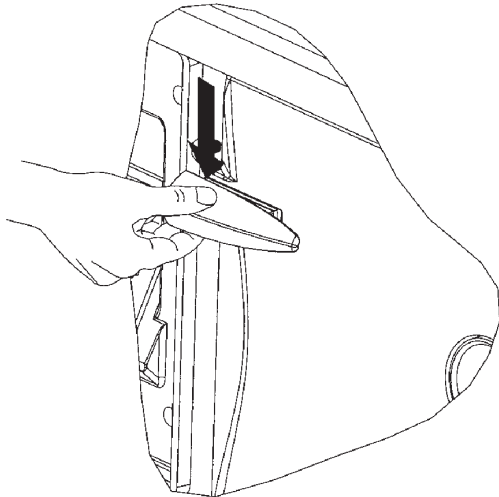

Fig.12

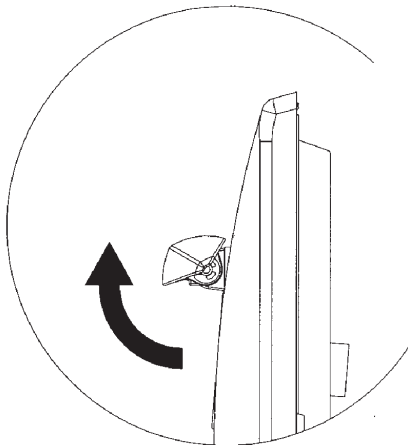

Fig.13

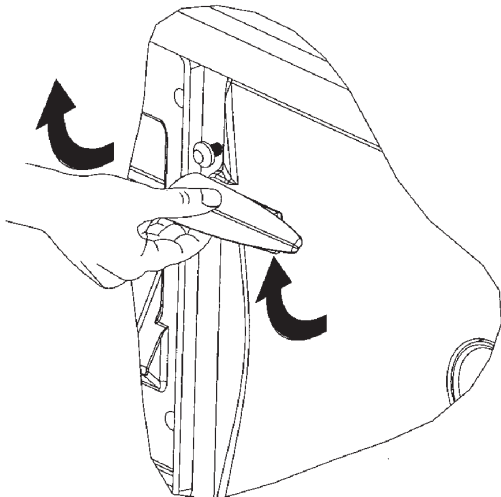

Fig.14

## CLEANING

### IMPORTANT: BE CAREFUL OF THE HOT APPLIANCE.

General cleaning must be carried out when the cooker is cool.

Stanley cookers are finished in a high gloss vitreous enamel. To keep the enamel in the best condition observe the following tips:

1. Wipe over daily with a soapy damp cloth, followed by a polish with a clean dry duster.
2. If milk, fruit juice or anything containing acid is spilt on the hob or down the cooker, be sure to wipe it immediately or the vitreous enamel may be permanently discoloured. Jam and preservatives containing sugar can permanently damage the vitreous enamel.
3. Keep a damp cloth to hand while cooking, to wipe up any spills as they occur, so they do not harden and become more difficult to remove later.
4. If spills do become baked on, a cream cleanser can be used. For stubborn deposits a soap impregnated pad can be carefully used on the vitreous enamel.
5. Use only products recommended by the Vitreous Enamel Association, these products carry the Vitramel label.

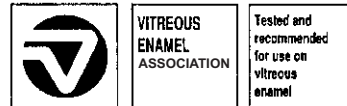

6. In the oven, spills and fat splashes are carbonised at high temperatures: occasionally brush out with a stiff brush. The shelves can be soaked and cleaned with a cream cleanser.
7. Both insulating covers should be raised and allowed to cool before cleaning the enamel with a soapy damp cloth. Use a wire brush to keep the cast iron hotplate clean.

**DO NOT USE ABRASIVE PADS OR OVEN CLEANERS CONTAINING CITRIC ACID ON ENAMELLED SURFACES. ENSURE THAT THE CLEANSER MANUFACTURERS INSTRUCTIONS ARE ADHERED TO.**

## CHIMNEY CLEANING

Whichever type of flue is chosen, there must be cleaning access to the whole of the flue system. The flue of the chimney will need to be cleaned regularly. The combustion products of any gas burning appliance will have a descaling effect on hardened soot deposits left from burning solid fuels.

---

Although, the chimney may have been cleaned of loose soot prior to installation, it is imperative that the chimney is inspected for scaled soot particles after the first month of operation and any loose material removed to avoid blockage.

## SERVICING

We recommend that the cooker and burner be serviced annually by an Authorised Stanley Service Engineer or a CORGI Registered Engineer.

## MILD STEEL

The steel side panels and splash back must not be cleaned with steel wool. Use only washing-up liquid in hot water with a lint free cloth. Dry off and apply a coat of good quality furniture polish.

## OVENS

Grease spillages will burn off from the oven interior when the oven is hot and any other loose materials can be emptied out with a cloth when cold. Stubborn stains in the oven and on the shelves can be cleaned off with a paste of bread soda and water.

## HOT PLATE

The hotplate may be cleaned using a small amount of paraffin oil or fine steel wool to remove rust or cooking stains, dry off with a lint free cloth and apply a light coat of cooking oil to preserve the finish.

## COOKING GUIDANCE

### GENERAL INFORMATION

#### GRILLING

Turn the oven thermostat to a reasonably high setting and this will give a greater temperature at the top of the main oven. The roasting tin supplied with the cooker contains a grill rack. Place any foods that require grilling onto the rack, and place the roasting tin as near to the top of the oven as possible. Any gratin type recipe that requires browning, place the dish on a shelf as near to the top of the oven as it will allow. For a delicious breakfast, lightly grease the base of the roasting tin and place slices of bread with a hole cut out of the centre, onto the base, carefully breaking an egg into each hole. Foods such as mushrooms and halved tomatoes can be placed around the eggs.

Place the grilling rack over the eggs and lay the bacon, sausage, black pudding etc., onto the grilling rack. The fat will drop onto the eggs, helping to cook and flavour them. Fatty foods such as lamb cutlets are best suited to this method of oven grilling, most of the fats are drawn out into the roasting tin. Certain foods with little fat, benefit from pan frying/dry frying on the hotplate, using a ribbed frying or griddle pan. The foods cooked this way look attractive with the bar markings from the pan.

## THE CARE OF YOUR COOKER

The vitreous enamel finish on your cooker is tough and hard wearing but should be treated with care. Acidic spills on the hob should be wiped off with a clean damp cloth. The vitreous enamel front, sides and hob only need a wipe with a warm soapy cloth, then a polish with a dry one. Do not use an abrasive cleaning material on the vitreous enamel. If there are stubborn marks on the hob, use a good quality enamel cleaner. Look for cleansers carrying the VEDC (Vitreous Enamel Development Council) Follow the manufacturers instructions carefully. The hotplate will carbonise any food spilt on it, which should be removed with a wire brush or metal scraper. This will ensure a good contact between cooking utensil and the hotplate. Take care when cleaning the insulating lids, the hotplate may be hot. The ovens are self cleaning, any food that spills on the oven floors will carbonise and can be brushed or scraped away. It is often easier to use the vacuum cleaner to remove all the bits.

## COOKWARE

You do not have to rush out and buy a new set of pans when you take delivery of your new Stanley cooker, but it is advisable to check your cookware. Thin, lightweight saucepans are liable to buckle, so it is recommended that you use saucepans which have a flat, thermic base. This design of saucepan will give you complete contact with the hotplate and maximum heat retention for a good cooking performance. This design is usually of 18/20 stainless steel, with the thermic base encapsulated onto the bottom of the pan. The base will have a core of aluminium sandwiched between two layers of stainless steel. The aluminium does not come into contact with the food while cooking, but will very quickly pick up the heat and evenly distribute it over the base of the pan. Some continental designs of saucepans will have this inner sandwich of aluminium, not only at the base but up the sides as well. Many people prefer the look of cast iron cookware. This cookware is just as versatile as stainless steel, absorbing and distributing the heat

---

evenly, and serving from the oven to table. They are available in a range of colours and designs, some with knobs and handles of a heat resistant material.

Good quality saucepans can be expensive to buy, but the versatility they offer means that fewer items need to be purchased. Oven proof earthenware will also produce satisfactory results. Your traditional cake tins, baking trays, loaf tins and any other favourite ovenware you use, will be suitable. There is bakeware on the market of Continental design which has a steel base, ideal for quickly absorbing the heat. It is covered with a magnum (enamel like) coating, which is safe to cook on, non stick effect and easy to clean. A roasting tin, containing the grilling rack is provided. You can use a pressure cooker on the hotplate but however, do check that the base of the pressure cooker makes good contact with the hotplate.

All timings in the cooking chart are guidelines only, as there are no set rules for roasting meat - each cut lends itself to several different ways of preparation and cooking and each family will have a preference. When meat is roasted quickly the juices are sealed in, preserving the full flavour, but there will sometimes be shrinkage. Some people prefer to slow roast at a lower temperature, a method that will reduce shrinkage and give a more tender joint.

Whichever roasting method you choose, the joint should first be weighed to calculate the cooking time. Place the meat on the grilling rack in the roasting tin, fat side uppermost. This will baste the meat as it is cooking, but check the roast from time to time and using a metal spoon, baste the meat yourself.

If you are using a meat thermometer, do take care when inserting it that it does not touch bone or excess fat. This will give you a false internal reading.

Stuffed joints of meat will need extra cooking time - approximately 10 minutes more for every 500g (1 lb).

<b>TYPE OF MEAT</b>	<b>TEMPERATURE</b>	<b>TIMING per 500g (1 lb)</b>
<b>BEEF ON THE BONE</b> SIRLOIN FORE RIB	180°C	RARE 10 mins + 10 mins over MED 12mins + 12 mins over WELL DONE 20 mins + 20 mins over
<b>BEEF BONED AND ROLLED</b> TOPSIDE TOP RUMP FILLET ROLLED RIB	180°C	RARE 12 mins + 12 mins over  MED 15 mins + 15 mins over WELL DONE 20 mins + 20 mins over
<b>PORK ON THE BONE</b> SHOULDER LOIN LEG	180°C	25 mins + 25 mins over
<b>PORK BONED AND ROLLED</b> SHOULDER LOIN LEG	180°C	30 mins + 30 mins over
<b>LAMB ON THE BONE</b> CROWN GUARD OF HONOUR LEG BEST END LOIN	180°C	MED 20 mins + 20 mins over WELL DONE 25 mins + 25 mins over
<b>LAMB BONED AND ROLLED</b>	180°C	MED 25 mins + 25 mins over WELL DONE 30 mins + 30 mins over
<b>VEAL BONED AND ROLLED</b> TOPSIDE SHOULDER FILLET	180°C	MED 20 mins + 20 mins over WELL DONE 25 mins + 25 mins over
<b>VENISON ON THE BONE</b> HAUNCH (LEG) SADDLE	180°C	RARE 12 mins + 12 mins over MED 15 mins + 15 mins over WELL DONE 20 mins + 20 mins over
<b>RABBIT/HARE</b>	180°C	Up to 1 kg (2 lb): 45 - 60 mins Up to 2 kg (4 1/2 lb): 60 - 90 mins
<b>CHICKEN</b>	190°C	20 mins + 20 mins over
<b>TURKEY</b> 3.6 - 4.5 kg (8 - 10 lb) 4.9 - 5.4 kg (11 - 12 lb) 5.4 - 6.3 kg (12 - 14 lb) 6.3 - 7.2 kg (14 - 16 lb) 7.2 - 8.1 kg (16 - 18 lb) 8.1 - 9 kg (18 - 20 lb)	160°C	3 1/2 - 3 3/4 hrs 3 3/4 - 4 hrs 4 - 4 1/2 4 1/4 - 4 1/2 hrs 4 1/2 - 4 3/4 hrs 4 3/4 - 5 hrs
<b>DUCK</b>	200°C	MED 25 mins + 25 mins over WELL DONE 30 mins + 30 mins over
<b>GOOSE</b>	180°C	20 mins + 20 mins over
<b>PHEASANT</b>	200°C	50 - 60 mins total cooking
<b>GROUSE</b>	220°C	30 - 45 mins total cooking
<b>PARTRIDGE</b>	220°C	45 mins total cooking

---

## USER COOKING TIPS

You will soon come to look upon the Stanley as a reliable companion to help you during a busy baking session or when you are preparing that extra-special meal. The following tips are ways in which you will find the Stanley invaluable: no doubt you will quickly add discoveries of your own to the list.

- 1. Baking:** If you are using butter or margarine from the refrigerator, simply place the required amount of fat in a heatproof bowl on the hob, near to the hotplate. It will be quickly brought to room temperature, making it easier to work with.
- 2. Breadmaking:** Stand the required liquid for the recipe in a heatproof jug on the hob near the hotplate to warm. Take care not to overheat as yeast is killed at high temperatures.
- 3. Breadmaking:** Depending on what mode the cooker is set at, the hob, plate rack or lower oven can be used for proving the dough.
- 4. Baking:** To dissolve gelatine, place two tablespoons of water or liquid from the recipe in a small heatproof bowl. Sprinkle the required amount of gelatine on the liquid and place on or near the hotplate to dissolve. A small stainless steel bowl is useful for this type of job.
- 5. Baking:** When melted chocolate is needed in a recipe or for decoration work, simply place the chocolate in a heatproof bowl near the hotplate. This method is easier than placing over a pan of hot water, which can often splash into the chocolate and spoil it.
- 6. Baking:** Syrup tins and jam jars with only a little left in them are easier to empty when they have warmed on the hob.
- 7. Cooking:** If a recipe requires a small amount of fried or softened onion, place the finely chopped onion and a little butter or oil in a heatproof bowl on or near the hotplate to soften. I use this method often, because it is so much easier than having to wash up a frying-pan! Many different types of vegetables can be prepared this way before adding to a recipe.
- 8. Cooking:** To make breadcrumbs, simply place the bread on a baking sheet in the lower oven and allow to dry out. Crush and store for future use.
- 9. Cooking:** To make croutons, cut the bread into small cubes, place in a shallow cast iron dish with a little oil and fry, using the base of the main oven. (If the oven is not in use, fry on the hotplate) Drain, spread out on a baking sheet and put to crisp in the lower oven. Croutons can be frozen for use when required.
- 10. Drying:** An abundance of fresh herbs need not be wasted. Place on a baking sheet, after washing and patting dry with kitchen paper, and leave to dry in the lower oven. Store for future use.
- 11. Drying:** Cooker rice can be spread out on a baking sheet and left to dry in the lower oven.
- 12. Baking:** When making fruit cakes, wash the dried fruit, place on a baking sheet and allow to dry off in the lower oven before use. Moist fruit will sink to the bottom of a cake and spoil it.
- 13. Preserving:** When you are bottling, the depth of the main oven makes it easy to sit a tray of bottled fruit all on the same shelf to cook in one session.
- 14. Preserving:** When you are making jam the graduated hotplate enables you to control the simmering of a large preserving pan much more easily than on a conventional cooker, where the pan is too large for the burner or ring. The warming of sugar, drying of the prepared fruit and the warming of jars and bottles can all be done with plenty of space using the lower oven and plate rack, if you have one.

WIRING DIAGRAM (DIGITAL TIMER) Fig.15

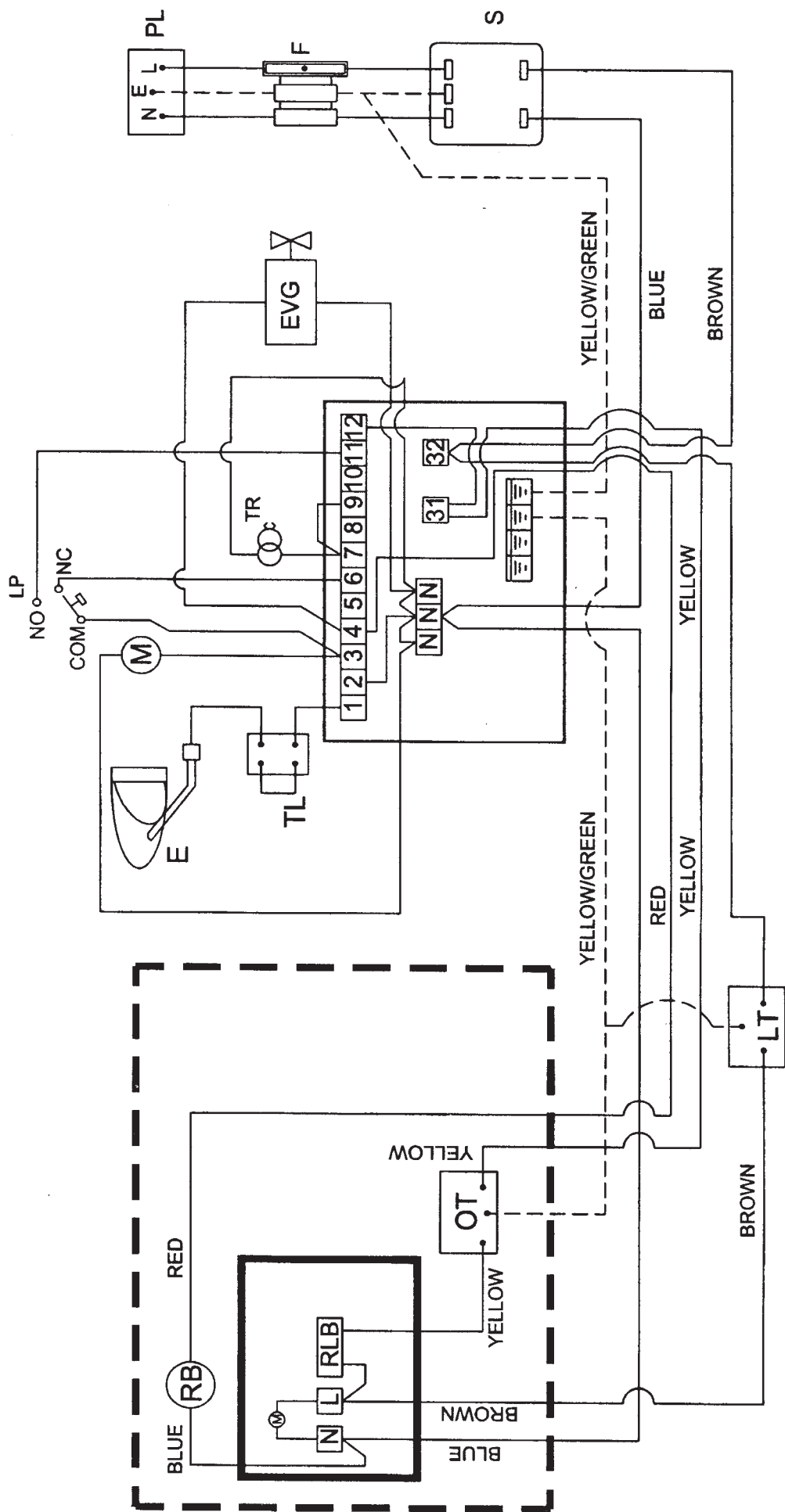



## FAULT FINDINGS

PROBLEM	CAUSE	REMEDY
1. Poor Flue Draught:	(a) Obstruction. (b) Chimney too low. (c) Chimney not lined. (d) Insufficient air supply.	(a) Clear and clean. (b) Raise height above ridge. (c) Fit flue liner 125mm (5") (d) Increase provision of free air for ventilation & combustion.
2. Excessive Flue Draught	(a) High chimney.	(a) Fit draught stabiliser (External)
3. Down Draught:	(a) High trees (b) High buildings (c) Low chimney. (d) Positive pressure zone.	(a) Raise chimney height. (b) Raise chimney height. (c) Raise chimney height. (d) Fit anti-down draught cowl.
4. Cooker Smoking:	(a) Insufficient primary air.  (b) Flue blocked or partially blocked (c) Downdraught. (d) Poor combustion.	(a) Provide additional room air inlet or adjust burner air intake.  (b) Clean flue. (c) Raise chimney height or fit anti-downdraught cowl. (d) Check air supply, check gas rate, and burner settings.
5. Hot Plate Not Heating:	(a) Burner cutting out. (b) Utensils not flat.	(a) Increase cooker thermostat setting. (b) Use machined based utensils.
6. Oven Not Heating:	(a) Flueways blocked or partially blocked. (b) Dirty flueways. (c) Insufficient gas supply. (d) Burner not set correctly.	(a) Clean out. (b) Clean flueways. (c) Check gas rate. (d) Commission burner correctly.
DHW Model Only	(e) Cylinder thermostat interruption.	(e) Release hot water from cylinder.

It is of the utmost importance to keep the flue pipe and chimney clear of deposits. Blocked or partially obstructed flueways and chimneys may cause dangerous fumes to be emitted into the room, these may well be invisible.

7. If the user detects a problem where the appliance will not function, there are two checks which can be carried out before calling your Local Service Agent.
  1. Check to see if the burner control box lock out reset button is illuminated, If so, press it and wait for burner to fire. If problem persists call you Local Service Agent.
  2. The user can also check the high limit reset button, follow procedure as outlined on page 5, if this fails to reset the appliance call your Local Service Agent.

**Manufactured by**  
**Waterford Stanley Ltd.,**  
 Unit 210, IDA Industrial Estate, Cork Road,  
 Waterford, Ireland.  
 Tel: (051) 302300 Fax (051) 302315

