

STANLEY

TURNING YOUR HOUSE INTO A HOME

Alpha 120/150K

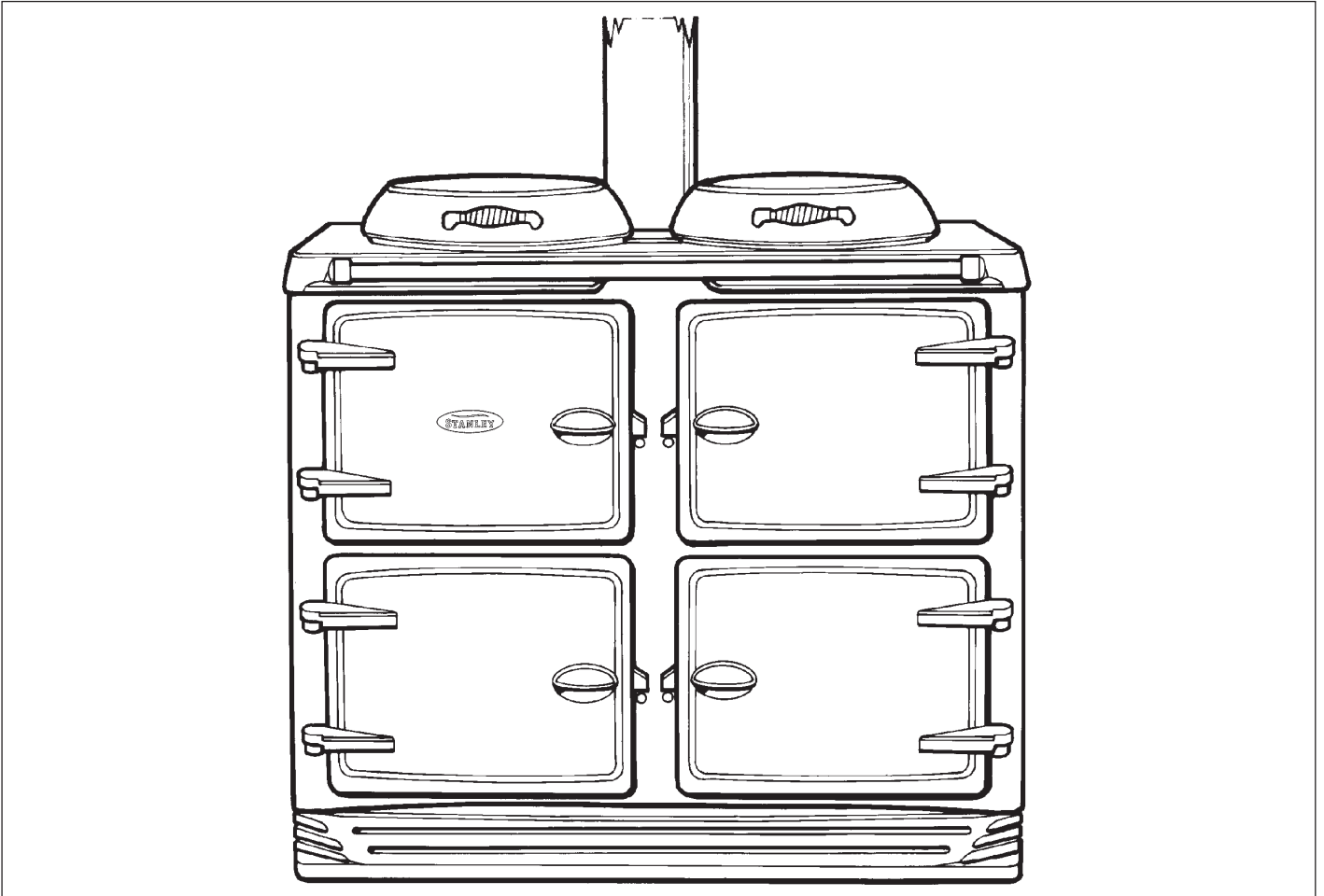

Site Requirements & Commissioning Instructions

THE STANLEY ALPHA COOKER IS DELIVERED EX-WORKS UNASSEMBLED. ASSEMBLY IS UNDERTAKEN ON SITE BY THE AUTHORISED ENGINEER.

REMEMBER, when replacing a part on this appliance, use only spare parts that you can be assured conform to the safety and performance specification that we require. Do not use reconditioned or copy parts that have not been clearly authorised by Waterford Stanley.

PLEASE READ THESE INSTRUCTIONS BEFORE INSTALLING THIS APPLIANCE

SECTION	CONTENTS	PAGE
	CONSUMER PROTECTION	3
	HEALTH AND SAFETY	3
	GENERAL SPECIFICATION	4
	TECHNICAL DATA	5
SITE REQUIREMENTS	INTRODUCTION	6
	REGULATIONS	6
	LOCATION	6
	OIL INSTALLATION	6
	OIL PIPE LINE	7
	OIL STORAGE	7
	GRAVITY FED ONE PIPE SYSTEM & TWO PIPE SYSTEMS	8
	FLUE SYSTEM	9
	AIR SUPPLY	10
	WATER CIRCULATION SYSTEM	10
	HEATING CONTROLS	11
	TIMING CONTROLS	11
	HEATING LAYOUT	11
	CONTROL WIRING	12
	CONNECTION	12
	ELECTRICAL SUPPLY	12
	EXTERNAL WIRING	13
	APPLIANCE WIRING	14
INSTALLATION REQUIREMENTS	CLEARANCES	15
	PRELIMINARY INSTALLATION	15
	AIR SUPPLY TO APPLIANCE	15
COMMISSIONING INSTRUCTIONS	BURNER ACCESS	16
	OIL CONNECTION	16
	FIRE VALVE	16
	ELECTRICAL CONNECTION	16
	TERMINAL STRIP CONNECTIONS	17
	ELECTRICAL CHECK	18
	FIT PRESSURE GAUGE	18
	VENT OIL PUMP	18
	ADJUST OIL PRESSURE	18
	SET COMBUSTION AIR	19
	ANCILLARY CONTROLS CHECK	20
	BOILER CONTROLS CHECK	20
	INSTRUCT THE USER	20
	SEALED SYSTEM REQUIREMENTS	21
	COMMISSIONING	21

Consumer Protection

As responsible manufacturers we take care to make sure that our products are designed and constructed to meet the required safety standards when properly installed and used.

IMPORTANT NOTICE: PLEASE READ THE ACCOMPANYING WARRANTY.

Any alteration that is not approved by Waterford Stanley could invalidate the approval of the appliance, operation of the warranty and could affect your statutory rights.

Health & Safety

This appliance may contain some of the materials that are indicated. It is the Users/Installers responsibility to ensure that the necessary personal protective clothing is worn when handling where applicable, the pertinent parts that contain any of the listed materials that could be interpreted as being injurious to health and safety, see below for information.

Firebricks, Fuel beds, Artificial Fuels

When handling use disposable gloves.

Fire cement

When handling use disposable gloves.

Glues and Sealants

Exercise caution - if these are still in liquid form use face mask and disposable gloves.

Glass Yarn, Mineral Wool, Insulation Pads, Ceramic Fibre

May be harmful if inhaled. May be irritating to skin, eyes, nose and throat. When handling avoid contact with skin or eyes. Use disposable gloves, face-masks and eye protection. After handling wash hands and other exposed parts. When disposing of the product, reduce dust with water spray, ensure that parts are securely wrapped.

Kerosene and Gas Oil (mineral oils)

1. The effect of mineral oils on the skin vary according to the duration of exposure.
2. The lighter fractions also remove the protective grease normally present on the surface of the skin. This renders the skin dry, liable to crack and more prone to damage caused by cuts and abrasions.
3. 'Oil acne' is recognised by the presence of skin rashes. The arms are most often affected, but may occur where there is contact with oil or oily clothing.
 - Seek medical attention for any rash.
 - Avoid skin contact with mineral oil or clothing contaminated with mineral oil.
4. Inhalation of mineral oil vapours must be avoided. Never fire the burner in the open as unburnt oil vapours are likely to occur.
5. Use a suitable barrier cream which will give protection against mineral oil, lanolin based hand creams are usually very effective.
6. Never syphon mineral oils by use of the mouth. If accidentally swallowed, call a doctor, do not induce vomiting.

NOTE: SMOKE/SMELL EMITTED DURING INITIAL USAGE

Some parts of the cooker have been coated with a light covering of protective oil. During initial operation of the cooker, this may cause smoke/smell to be emitted and is normal and not a fault with the appliance, it is therefore advisable to open doors and or windows to allow for ventilation. Lift the lids to prevent staining the linings.

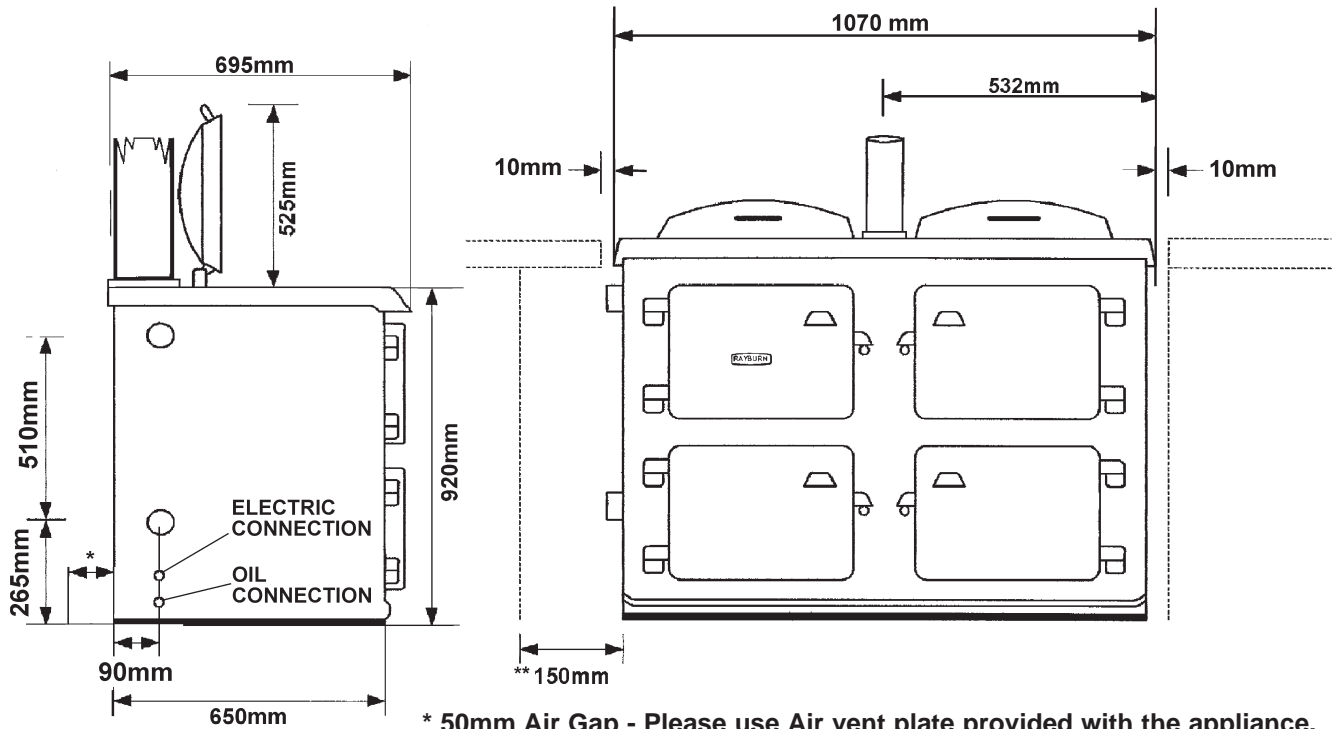

* 50mm Air Gap - Please use Air vent plate provided with the appliance.
 ** Clearance recommended for access to services. An infill fascia can be used to close off gap.

FIG. 1

DESN 514745 A

GENERAL SPECIFICATIONS

Boiler Water Connections

Flow (one) Rp1 (1in. BSP Int)
 Return (one) Rp1 (1in. BSP Int)

Both connections are located towards the rear edge of the appliance L.H. side panel.

Oil Inlet 10mm Copper to connect from LH side panel

Electrical Supply 230V ~ 50Hz 210 W
 3 Amp Fused

Flue Outlet 125mm

CO₂%
 - BOILER 11 - 11.5%
 - COOKER 11 - 11.5%

Max. Water Temp. 82°C

Water Capacity of Boiler 18 Litres

Weight of Appliance 498kg

Max. Operating Pressure of Boiler 3 bar

Fuel - Kerosene C2

Max. flue gas temp. - 250°C

Technical Data

120K	BOILER BURNER	COOKER BURNER
BURNER NOZZLE (US g/h)	1.00 (80°H)	0.35 @ 80°S
OIL PRESSURE Bar (psi)	10 bar (145)	10 bar (145)
OIL BURNING RATE cc/m	70 cc/min	24 cc/min
HEAT INPUT kW	42 kW	15.0 kW
BOILER OUTPUT kW	37 kW	

150K	BOILER BURNER	COOKER BURNER
BURNER NOZZLE (US g/h)	1.20 (60°EH)	0.35 @ 80°S
OIL PRESSURE Bar (psi)	10 bar (145)	10 bar (145)
OIL BURNING RATE cc/m	87.5 cc/min	24 cc/min
HEAT INPUT kW	53 kW	15.0 kW
BOILER OUTPUT kW	43.8 kW	

INTRODUCTION

The Stanley Alpha is a floor standing combined cooker and central heating boiler. It gives independent operation of space heating, domestic hot water and cooking.

The appliance is fired by two independent pressure jet oil burners. Either burner can be independently operated under the programmer control if required.

The boiler is designed for use on a fully pumped, low pressure hot water circulation system with a pumped over run facility. It may be an open vented or alternatively a sealed system limited to 3 bar.

IMPORTANT

- **This appliance must only be used with Kerosene C2 to BS 2869.**
- **An Indirect Cylinder to BS 1566: Part 1 must be fitted.**
- **If the heating circuits are controlled in such a way that both heating and cylinder circuits can be closed off at the same time then a BYPASS LOOP must be fitted.**
- **An OFTEC approved Fire Valve MUST be fitted in the oil supply line.**
- **The supplied in line filter MUST be fitted.**
- **Permanent Ventilation must be provided.**

REGULATIONS

THIS APPLIANCE IS A CONTROLLED SERVICE BY DEFINITION AND REQUIRES EITHER FITMENT UNDER THE REMIT OF BUILDING CONTROL OR INSTALLATION BY AN OFTEC REGISTERED 105 TECHNICIAN (CLASSED AS A COMPETENT PERSON) WHO CAN SELF CERTIFY HIS OWN WORKS.

The appliance must be commissioned by a competent engineer. Failure to install the appliance correctly could lead to prosecution.

The installation of the appliance must be in accordance with the relevant requirements of the current Building Regulations in force and the bylaws of the local Water Undertaking. It should also be in accordance with the relevant current British Standard Codes of Practice.

BS5410 Installation of oil fired appliances for space heating and hot water supply purposes. Part 1 Boiler of rated output not exceeding 45kW.

BS5449 Central Heating for domestic purposes, Part 1. Forced circulation hot water system.

Building Regulations England & Wales. Part J. Heat producing appliances.

Building Standards Scotland - Technical Standard Part F. Heat producing appliances and storage of liquid and gaseous fuel.

Building Regulations (Northern Ireland) Part L - Heat producing appliances.

The Control of Pollution (Oil) Regulations.

LOCATION

Location and Siting of the Appliance

To choose a location for the Stanley Alpha, the following must be considered:

- a. Satisfactory provision for installation of the flue.
- b. A solid non-combustible hearth.
- c. Sufficient space for installation.
- d. Adequate space for combustion air vents (rear of cooker).
- e. Sufficient forward space must be available to allow the right hand doors to be opened, in excess of 110° from the closed position.

Hearth Construction

The hearth or base on which the appliance will stand must be of sound construction, being able to bear the weight of 498 Kg) the appliance. This must be of a non-combustible material and must be level.

The location chosen for the appliance must permit the installation and the provision of a satisfactory flue and an adequate air supply. The location must also provide adequate space for servicing and air circulation around the appliance.

In addition, adequate clearance must be available at the front of the appliance to enable it to be operated and serviced. Flue pipes and fittings must not be closer than 25mm to combustible materials and where passing through a combustible partition such as ceiling or roof, must be enclosed in a non-combustible sleeve providing an air space of at least 25mm.

Space around the flue pipes passing through walls or floors should be sealed against the passage of smoke and flame. A fire stop must be provided where the flue passes through a ceiling.

Where the cooker is to stand in a recess or against a wall which is to be tiled, **in no circumstances should the tiles overlap the cooker top plate.**

OIL INSTALLATION

The installation of the oil supply must be carried out in accordance with current building regulations and OFTEC recommendations.

It is the installers responsibility to correctly plan and size the siting and fitting of the oil tank and run of pipework to the appliance, ensuring that the oil tank is suitably sized for the model of Stanley Alpha in use and that the oil supply pipe is run correctly i.e. a two-pipe system **NOT A DE-AERATION DEVICE** if the tank position is lower than the appliance.

Site requirements

OIL PIPE LINE

The oil supply connection between the storage tank and the oil pipe should be run in copper pipe with a minimum diameter of 10mm. Galvanised pipes and fittings should not be used. Annealed copper pipe is preferred with a flare type manipulative fittings. Capillary fittings with soft solder should not be used. Steel pipes should be joined using taper threads.

All pipework and fittings must be completely air tight. Only oil resistant compounds and PTFE tape should be used when making joints. Pipe work must be protected against damage whether fitted above or below ground.

The size and arrangement of pipe work will depend upon the distance and height of the oil storage tank in relation to the oil pump inlet.

The oil line from the storage tank to the appliance must be fitted with a remote acting OFTEC approved fire valve operating at 150°F, fitted with an appropriate length of capillary to enable the valve body to be located externally at the point where the oil line enters the building, 0.5 metres of capillary will be required to insert into the appliance at the phial end.

The 5-10 micron oil filter supplied with the appliance must be fitted to the oil pipe and stop valve must be fitted as close to the cooker as possible in an accessible position.

A flexible pipe connection, approximately 1000mm long, is supplied to fit between the oil supply pipe and the oil pump for ease of burner removal. This must be contained within the appliance.

OIL STORAGE

The minimum recommended oil tank size is 1400 litres and the code of practice governing its installation are covered by BS 5420: Part 1. Mild Steel tanks should be to BS 799: Part 5 and plastic tanks to OFTEC Standard OFS T100.

TWO PIPE SYSTEM KIT

A kit is available for a two-pipe system (optional extra).

Part No: RO9M 998550

Cat No: R4613

The kit is made up of the following parts:

Bulkhead Fitting
Flexi Hose
Return Oil Nipple
Two Pipe System Fitting Instruction

Conversion to a 2-pipe system

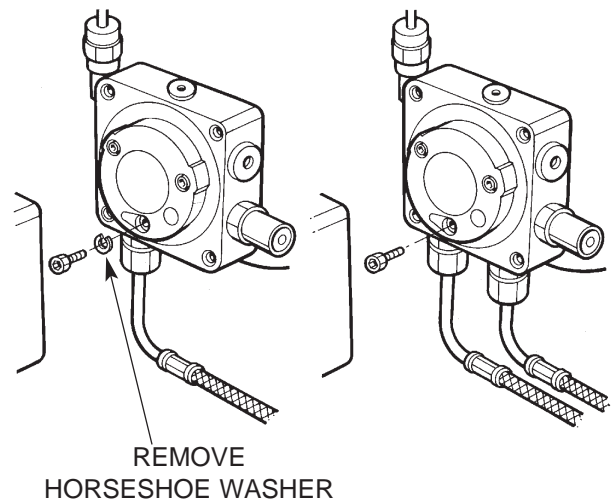

FIG. 2

DESN 511990

Gravity Fed One Pipe System

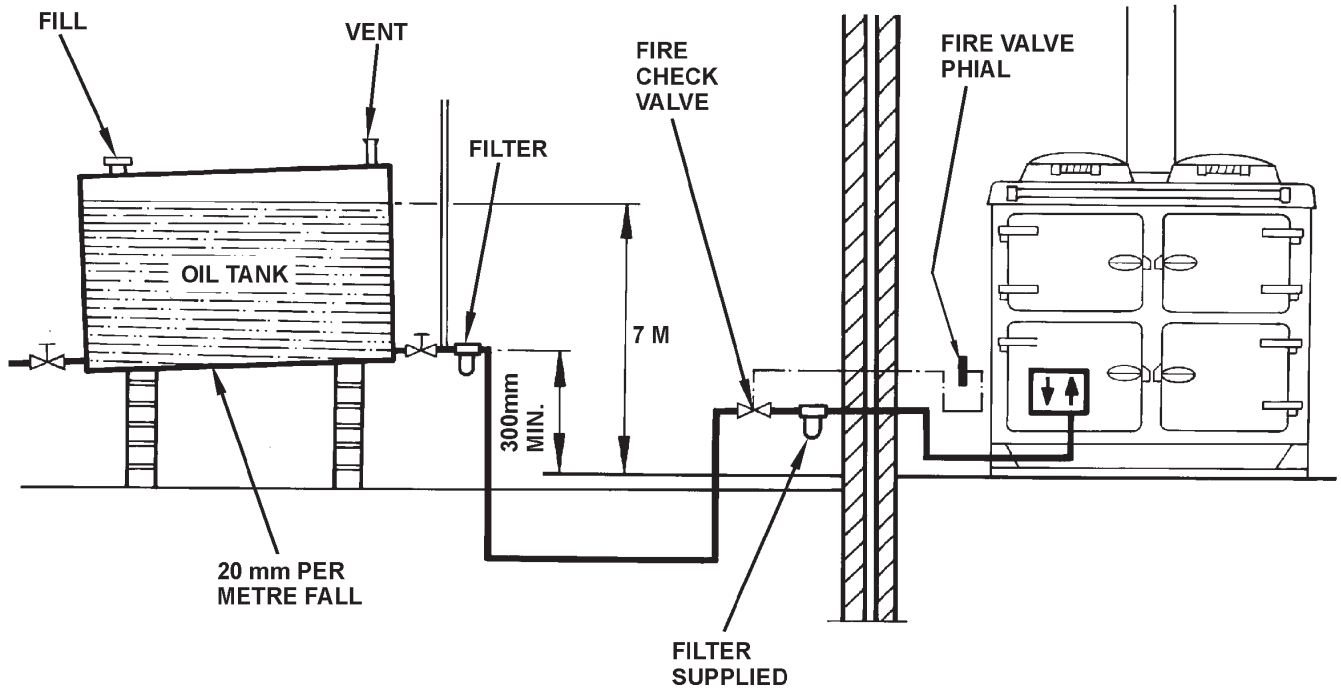
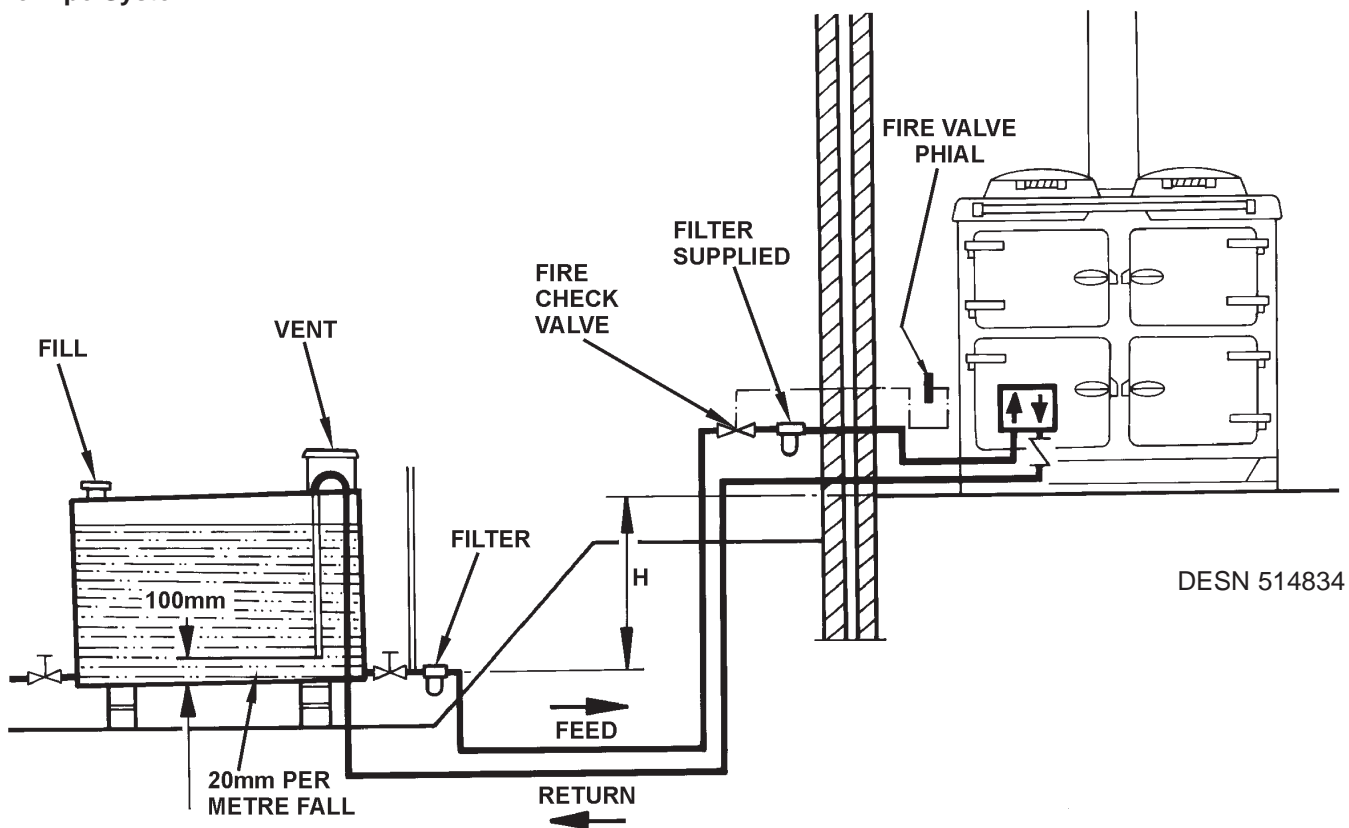

FIG. 3

DESN 514833

Two Pipe System



DESN 514834

FIG. 4

	H METRES	0	0.5	1.0	1.5	2.0	2.5	3.0
MAXIMUM LENGTH (METRES)	10mm OD	35	30	25	20	15	8	6
	12mm OD	100	100	100	90	70	30	20

Site requirements

FLUE SYSTEM

The flue system must be installed in accordance with the regulations in force.

Information

Maximum flue gas temperature 250°C

(Both burners on)

Minimum flue gas temperature 125°C

(Boiler burner on only)

The appliance requires a minimum chimney draught of 1.0mm (0.04 WG) with both burners on.

Maximum chimney draught 6.0mm (0.23" WG) draughts in excess of this figure will require a draught stabiliser, fitted either in the chimney or flue pipe and in the same compartment.

It is recommended that the 120K model is connected to a flue liner no less than 125mm (5") diameter. It is recommended that the 150K model is connected to a flue liner no less than 150mm (6") with the flue adaptor no more than 1 metre above the appliance.

Detailed recommendations for flueing in England and Wales are given in Part J of the Building Regulations. For Scotland in Technical Standard F to the Building Standards and in Northern Ireland in Technical Booklet L to the Building Regulations. Guidance is also given in BS5410: Part 1.

Due to the range in flue gas temperatures a brick chimney should be fitted with a suitable multi-fuel stainless steel flexible liner. Where it is necessary to avoid condensation, such as an exposed end gable, the lining may be wrapped with a proprietary insulating bracket.

NOTE: TO ACHIEVE THE OPTIMUM OPERATIONAL SOUND LEVELS FROM THE APPLIANCE IT IS RECOMMENDED THAT CAST IRON FLUE PIPE IS USED WHERE POSSIBLE.

Chimney Termination

All chimneys should terminate at least 600mm above the roof level in accordance with current Building Regulations and statutory requirements as outlined in BS 5410: Part 1, BS 6461: Part 1 and BS 7566 Parts 1 to 4.

Chimney Cleaning

Ensure there are accessible airtight flue cleaning doors in order to obtain cleaning access to the complete chimney. Providing the appliance is operating correctly, an annual chimney flue cleaning will suffice, but if in doubt arrange for a half yearly clean, preferably at the beginning/end of the heating season.

Installation of a conventional flue

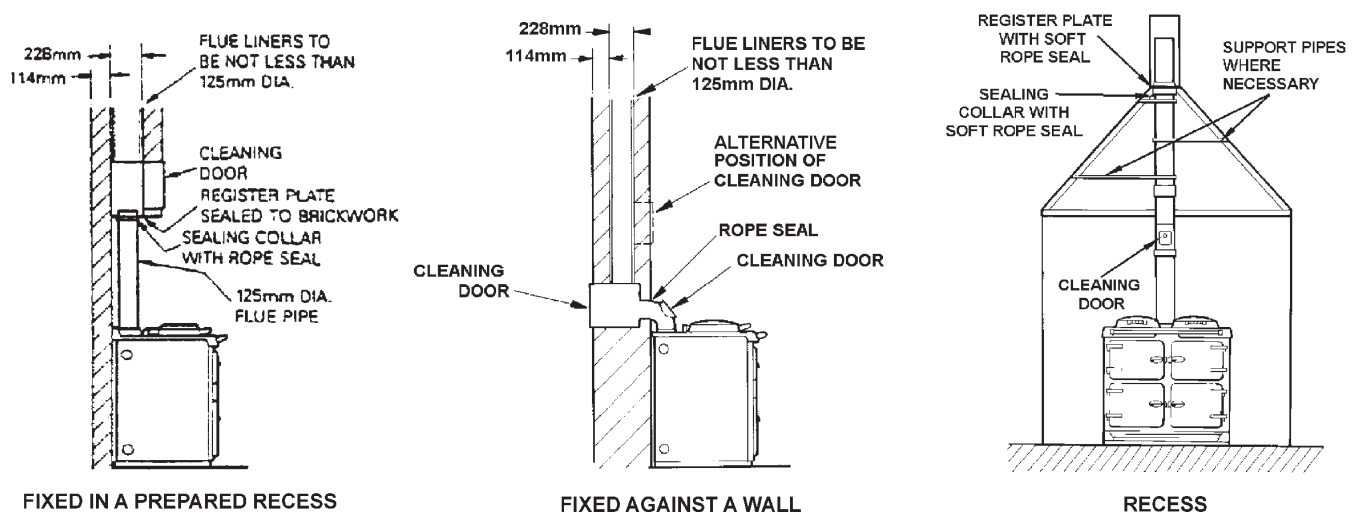

FIG. 5

DESN 514844

AIR SUPPLY

This appliance can only be installed in a room which meets the ventilation regulations in force. But, in any event the room must have a permanent vent of minimum free air area, see below.

MODEL	MIN. AIR REQUIREMENT
120K	250cm ²
150K	290cm ²

IMPORTANT: THE LOUVERED AIR INTAKE AT THE BOTTOM FRONT OF THIS APPLIANCE MUST BE KEPT CLEAR OF ANY OBSTRUCTIONS.

Detailed recommendations for air supply are given in the Building Regulations and in BS 5440: Part 1. The following notes are intended to give general guidance.

1. Combustion and ventilation air supply to oil fired appliance has to comply with the Building Regulations and with BS 5410: Part 1. The air supply requirement for oil fired appliance in 550mm² per kW of maximum rated output above 5 kW. These requirements are illustrated in OFTEC Technical Book No. 3.
2. The combustion air supply to open flued appliances should normally be provided at high level into a room where it will not cause discomfort by creating a cold draught across the floor.
3. If combustion air is supplied through an under floor duct the grilles at each end should be positioned in the vertical plane to reduce the risk of blockage. Ducts should be sized so as to reduce the resistance to air flow.
4. The ventilation requirement for kitchens in Part F of the Building Regulations (England & Wales) is for mechanical extract at the rate of 60 litres per second or 30 litres per second if the fan is incorporated in a cooker hood. The amount can be reduced if the spillage of flue gases might be caused by the outflow of air from the room.

Background ventilation is also required, either by producing a constant extract rate of one air change per hour or by having ventilation openings not less than 4000mm².

5. Extract fan should be positioned as far away from the open flue as possible and should have a sufficient dedicated air supply. To undertake a test the oil fired appliance should be set in operation and the doors and windows of the room containing it should be closed. The extract fan should then be run at its maximum setting. The oil fired heating appliance should be observed to operate satisfactorily both before and after the fan is switched on.

6. It is preferable for the air supply for an extract fan to be located where it can serve the fan without the air stream passing close to the oil fired appliance.
7. Oil fired appliances must not draw the combustion air from a garage.

WATER CIRCULATION SYSTEM

Flow and return pipework between cooker diverter valves must be 28mm diameter minimum.

Space and water heating systems should be in accordance with the relevant recommendations of BS 5410: Part 1.

In a combined central heating and domestic hot water system, the hot water storage vessel must be of the indirect cylinder type to BS 1566: Part 1. The hot water storage vessel should be insulated with not less than 75mm thick mineral fibre or its equivalent.

Cisterns and pipework should not be situated in areas which may be exposed by freezing conditions should be insulated.

Draining taps must be located in accessible positions which permit the draining of the whole system, including the heat storage vessel. Draining taps should be at least 1/2in BSP nominal size and be in accordance with BS 2879.

The appliance boiler section should be connected to a cistern water supply, subject to a maximum head of 18.25m. The heating system must be designed (and adjusted if necessary) to give temperature differential across the boiler at full output of 10-14°C. When horizontal runs are used the pipes should rise upwards in the direction away from the appliance.

Circulating Pump

It is recommended that the selected pump be sized to suit the boiler pressure loss and therefore adequate to give the required temperature differential between the flow and return.

The pump should be able to meet the requirements of the system design and fitted in a readily accessible position.

Isolating Valves

Isolating valves (preferably of the keyless type) must be fitted to the inlet and outlet of the circulating pump to facilitate service and replacement of pump without draining the system.

Inhibitor

A corrosion inhibitor **MUST** be added to the heating system to protect the heat exchange and pipework. Inhibitor must also be replaced if the system is drained after installation. As a precaution the heating system **MUST** also be flushed out prior to the addition of the inhibitor to ensure any flux, debris is removed.

Site requirements

HEATING CONTROLS

A 3-channel programmer controls the Stanley Alpha cooker: two of these channels are used for the boiler control integrated with a room stat and a cylinder stat and two motorised zone valves. This in turn gives full control of the central heating and domestic hot water independently.

The cooker has a built in pump overrun control stat so the pump runs only when required or in the case of excess build up of heat.

Consideration should be given to fitting a frost thermostat switch, which should be set to operate at a temperature of approximately 4°C.

Consideration must be given when selecting 3 port mid-position or 2 port zone valves.

It is essential that the capacity of the individual valves are considered to enable the correct size to be chosen.

For this range of appliance, where Honeywell valves are selected, a guide to selection is as follows:-

Model:-

8120K - 28mm (1")	2 port only
8150K - 28mm (1")	2 port

TIMING CONTROLS

The latest publication of Part L of the Building Regulations states that "separate timing controls should be provided for space heating and water heating".

The 800 Series cookers/boilers are supplied with a 3-channel programmer.

Channel 1 controls the cooking facility.

Channel 2 & 3 controls the boiler facility which is space heating and water heating.

WARNING: POWER TO THE APPLIANCE AND AUXILIARY CONTROLS i.e. PROGRAMMABLE ROOM STAT MUST BE VIA THE SAME ISOLATION SWITCH.

HEATING LAYOUT

Please refer to Fig. 26.

Site requirements

CONTROL WIRING

The cooker combined with the 3-channel programmer will operate the heating, hot water and cooking individually.

The control wiring must be as the following diagrams. Alteration to this could cause the appliance to overheat and fail.

The cooker is fitted with high limit and pump overrun control thermostats, which protect the appliance in normal operation. Failure to wire the appliance correctly could result in these protective controls/devices not operating or operating incorrectly.

CONNECTION

Connection of the wiring is made in the bottom left hand side of the cooker.

Connection is made with a 11-way terminal block.

The appliance requires a 3 amp supply via switched fused spur or switched isolator.

There is then a protected supply out to the programmer and any other devices requiring power. Switched lives are then returned for the burners, via the room and cylinder stats.

ELECTRICAL SUPPLY

Wiring external to the appliance must be installed in accordance with current National Wiring Regulations and any local regulations which apply. The appliance is supplied for 230 Volt - 50 Hz 210W a fuse rating of 3 amps. The method of connection to the mains supply should facilitate complete isolation of the appliance, by the use of a fused double pole switch having a contact separation of at least 3mm serving only the appliance.

The point of connection to the mains should be readily accessible and adjacent to the appliance. The installation should be protected by a 30mA Residual Current Circuit Breaker (RCCB).

The minimum requirement for the power cable is that it should be a 3 core PVC sheathed flexible cord (85°C min) at least 0.75mm² (24 x 0.2mm) to the relevant standard.

WARNING: THIS APPLIANCE MUST BE EARTHED.

In the event of an electrical fault after installation of the appliance, preliminary electrical system checks must be carried out i.e. earth continuity, polarity and resistance to earth.

For wiring instructions, see wiring diagrams.

The circulating pump must be connected to PL and PN on the terminal block (See Fig. 6) and the cables clamped and passed through the grommet in the left hand side panel.

NOTE: The 3 amp fuse rating takes into account any AUXILIARY components used. In most central heating systems i.e. circulation pump, zone valves. Aga recommend that only CE marked equipment is used in conjunction with this appliance.

Site requirements

External wiring with 2 zone valves

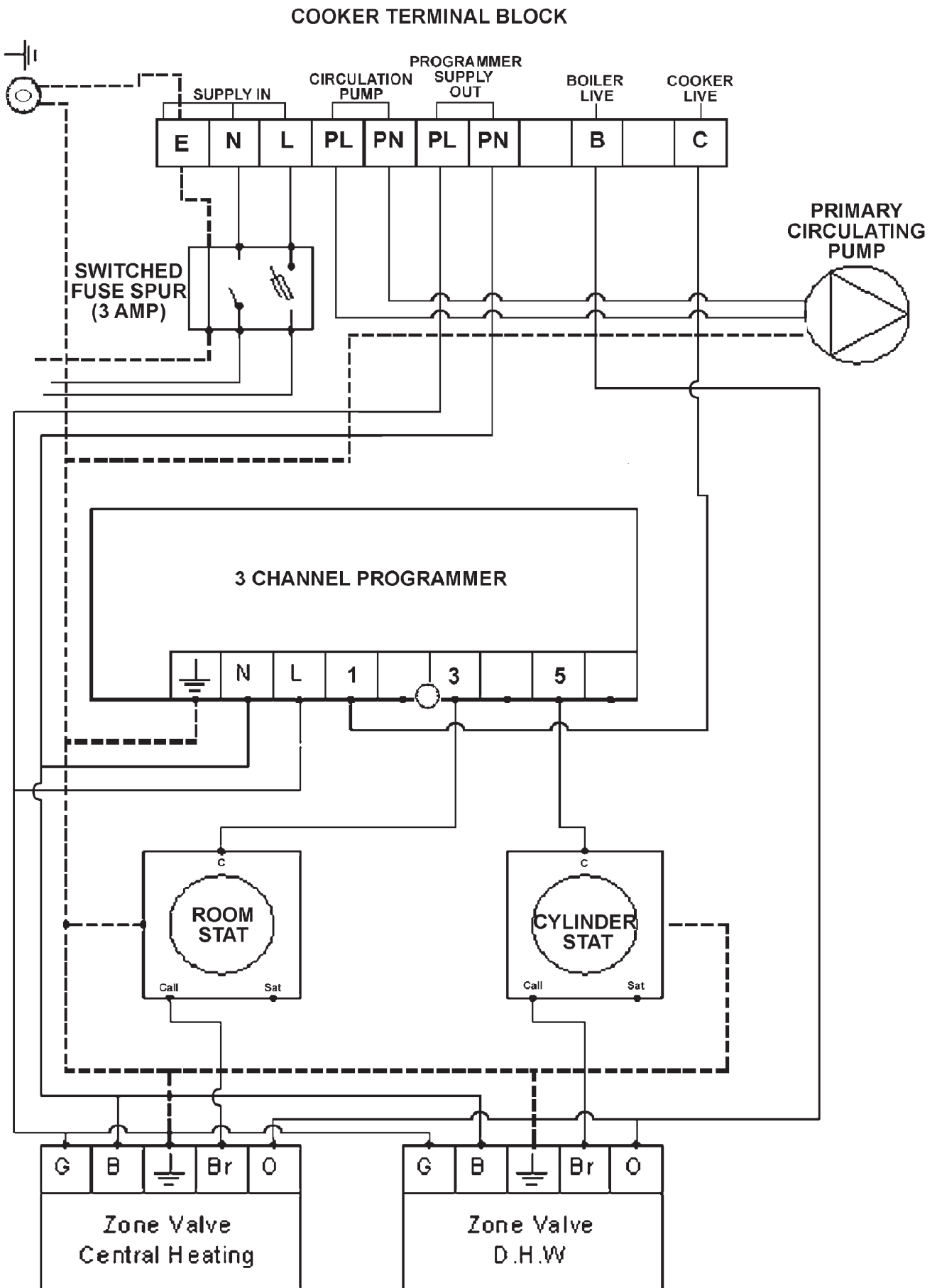

FIG. 6

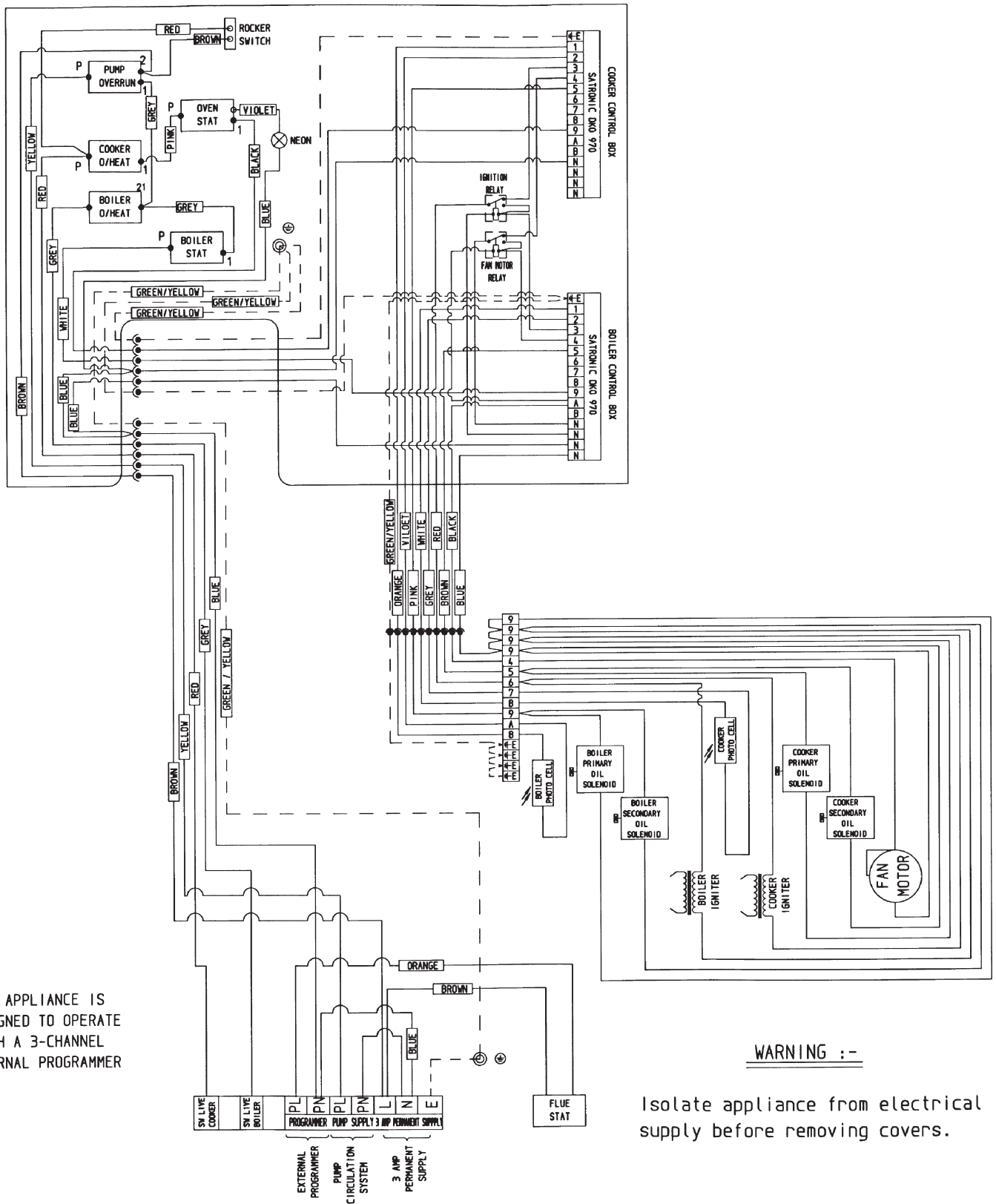

FIG. 7

Installation requirements

CLEARANCES

This appliance is floor mounted. The space in which the appliance is to be fitted must have the following minimum dimensions:

Between wall and LH side of appliance: 10mm - Access to services is required LH side. 150mm clearance recommended. (See Fig. 1).

Between wall and RH side of appliance: 10mm

SHOULD THE WALL PROJECT BEYOND THE FRONT OF THE APPLIANCE, WHEN IT MUST BE INCREASED TO 50mm.

Above the raised insulating cover - 60mm

In addition adequate clearance must be available at the front of the appliance to enable it to be operated and serviced.

PRELIMINARY INSTALLATION

NOTE: THE STANLEY ALPHA COOKER IS DELIVERED EX-WORKS UNASSEMBLED. ASSEMBLY IS UNDERTAKEN ON SITE BY AN APPROVED ENGINEER.

With the exception of the following:

1. Flue connection
2. Oil connection (Oil filter supplied with cooker)
3. Water connection
4. Electrical connection

AIR SUPPLY TO APPLIANCE

The appliance must be spaced from the wall by 50mm and the air vent plate must be fitted and unrestricted.

BURNER ACCESS

SEE FIG. 8

1. Open the burner access door. Remove door and put in a safe place.
2. Remove 2 inner panel securing screws and remove panel.

OIL CONNECTION

SEE FIG. 9

1. Route 10mm copper oil feed pipe through left hand side grommet and into the base of the appliance.
2. Connect to 10mm compression bulkhead fitting.

NOTE: When using two-pipe system knit order kit number - R09M 998550.

3. Route second pipe as first.

FIRE VALVE

SEE FIG. 9

1. Route fire valve capillary through grommet on left hand side panel and clip into the 2 clips provided.
2. Ensure that the fire valve is routed to allow free removal of the burner assembly.

ELECTRICAL CONNECTION

SEE FIG. 10

1. Route all electrical cables through top grommet in the left hand side panel.
2. Make electrical connections to terminal strip as wiring diagram.
3. Secure using cable clamp provided.

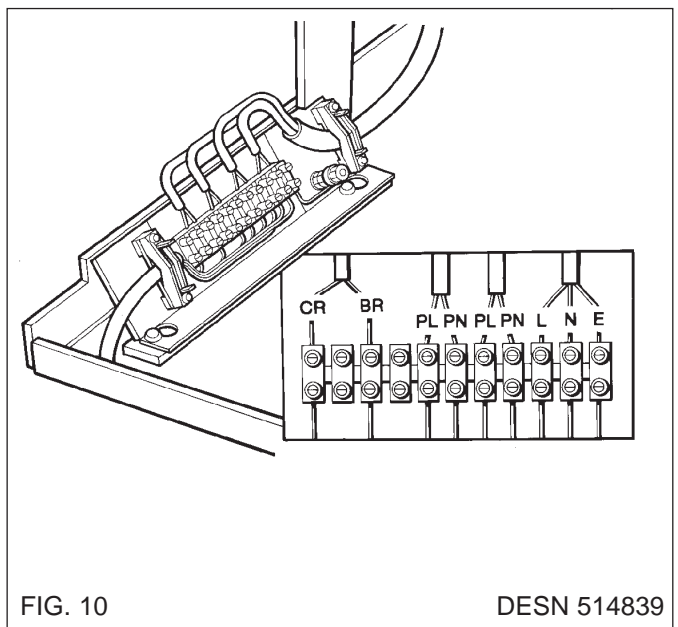
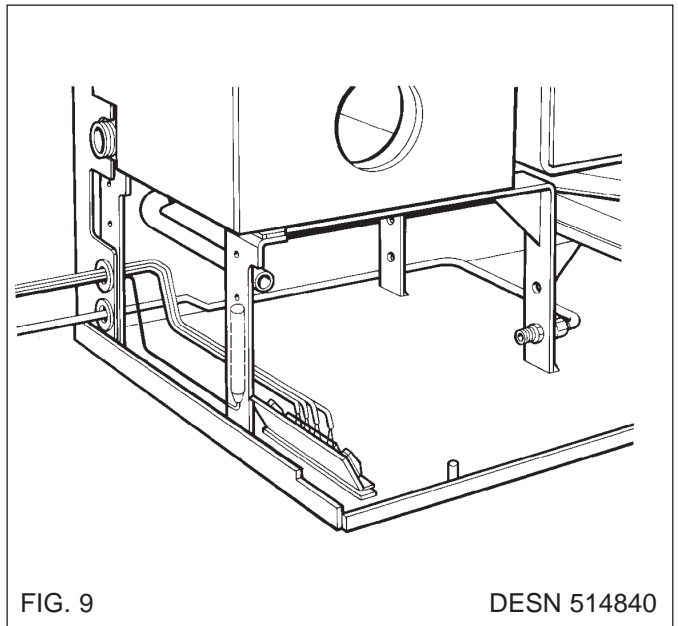
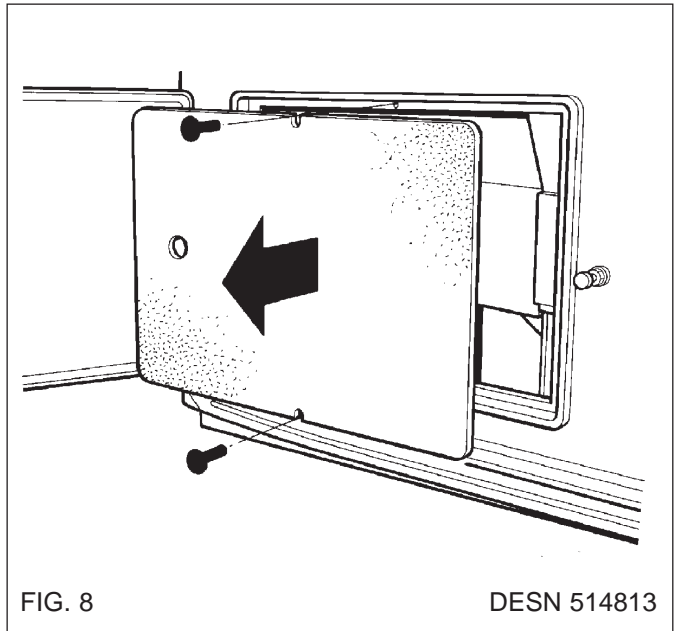

Commissioning Instructions

TERMINAL STRIP CONNECTIONS

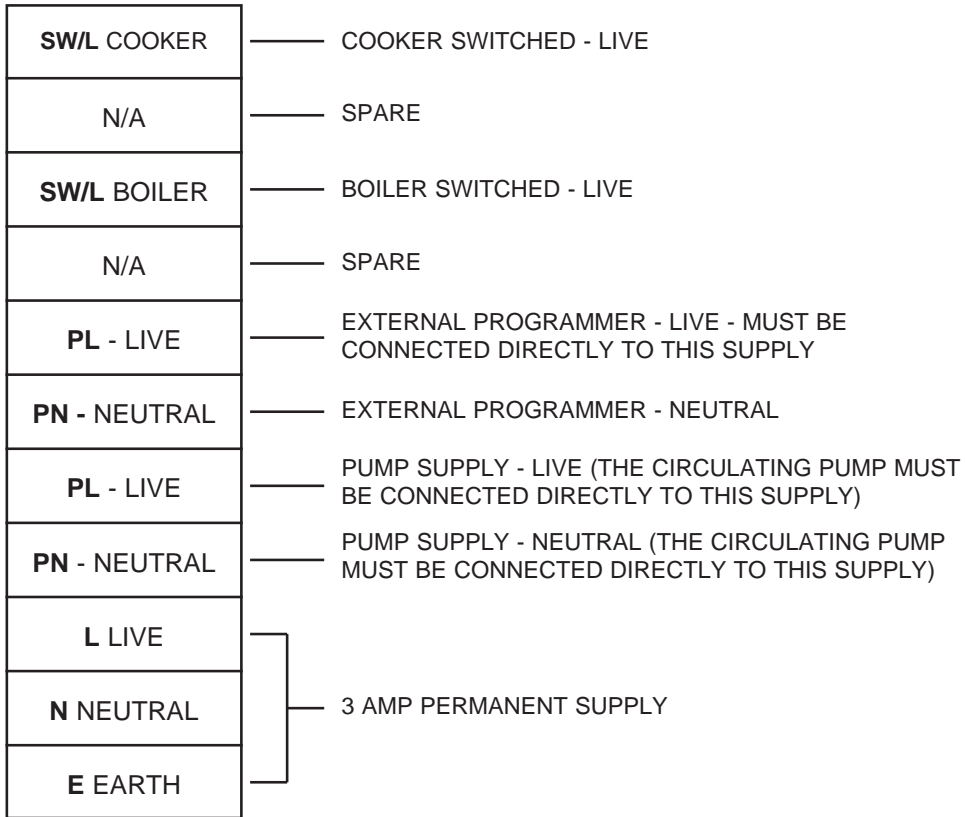

NOTE:

The 3 channel programmer **LIVE** must be connected directly to the programmer **LIVE** supply from the cooker.

FIG. 11

Commissioning Instructions

ELECTRICAL CHECK

Checks to ensure electrical safety should be carried out by a competent person.

Switch on the Electricity

FIT PRESSURE GAUGE

SEE FIG. 12

Remove the bleed screw from the manifold and fit an oil pressure gauge with R 1/8 connection to check the pump output pressure.

Set the boiler burner time clock switch to continuous and turn the boiler thermostat to maximum. The boiler burner should run on pre-purge for 7-15 seconds, with the ignition spark energised. The solenoid valve should then open allowing the burner to fire.

Until all the air from the oil pump is flushed out there may be some flame instability resulting in the burner locking out.

This will be shown by the burner stopping and the illumination of the signal light in the reset button of the control box. In this event, wait at least 30 seconds, then press the re-set button to restart.

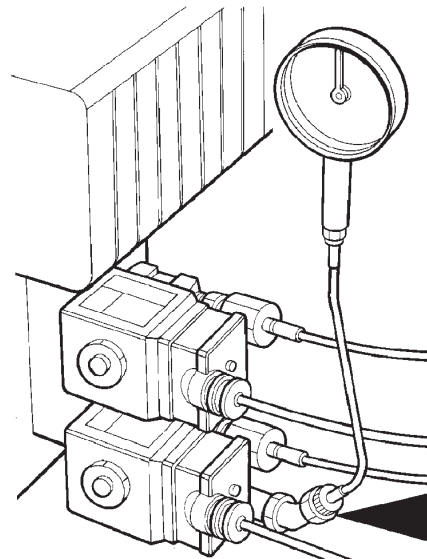

FIG. 12

DESN 514825

VENT OIL PUMP

SEE FIG. 12

Whilst the burner is running, vent air from the pump by slackening the pressure gauge connection sufficient to allow air to bleed out. When bubble free oil seeps out re-tighten.

ADJUST OIL PRESSURE

SEE FIG. 13

Whilst the burner is running check the oil pressure on the pressure gauge.

If the pressure gauge is not indicating the correct reading then adjust the pressure by turning the pressure regulator clockwise to increase or anti-clockwise to decrease the pressure until the pressure gauge reads 10 bar (145 lb/in²).

Switch off the burner, remove the pressure gauge and refit the bleed screw.

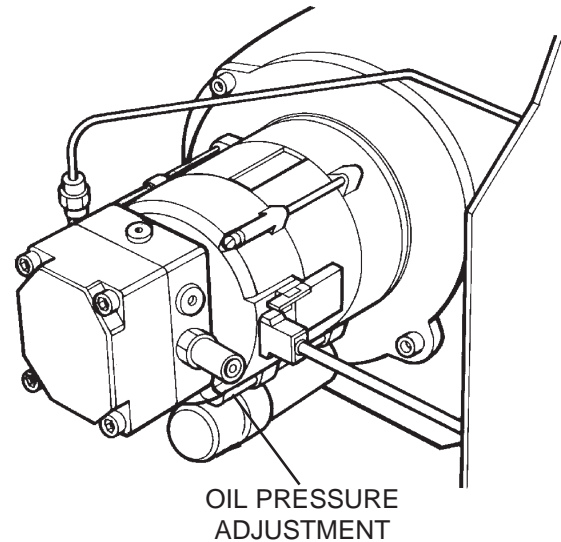

FIG. 13

DESN 511997

Commissioning Instructions

SET COMBUSTION AIR

SEE FIG. 14, 15, 16 & 17

The air controls of the burners are factory pre-set, however small adjustments maybe necessary to suit the site conditions. (See Fig. 16).

With the cooker isolated, remove the control panel facia and hang control panel face-down. (See Fig. 17)

Turn on electrical supply and turn the boiler on.

After 15 minutes, remove the plugging screw and insert the sensing end of a portable indicator to check the CO₂ (Carbon Dioxide) level. Adjust the boiler burner air intake until a reading of 11-11.5% CO₂ is recorded on the indicator.

Check Smoke

Remove the CO₂ sampling tube, using the same hole for flue sampling insert the sensing end of a Baccarach Smoke Pump and check that the smoke in the boiler flue ways does not exceed No. 2 on the scale. Replace the plugging screw, re-assemble control panel facia.

Switch off the boiler burner and repeat the procedure with the cooker burner.

Cooker Burner

After 15 minutes running sample the flue gases from the cooker burner. Lift up the RH insulating cover and remove the countersunk headed screw in the hotplate. The cooker burner should be set to 11.0-11.5% CO₂ with a maximum smoke No. 2. Replace the countersunk headed screw on completion ensuring that it will not interfere with any pots and pans placed on the hotplate.

When satisfied with combustion check, refit burner door inner panel.

Refit outer burner door.

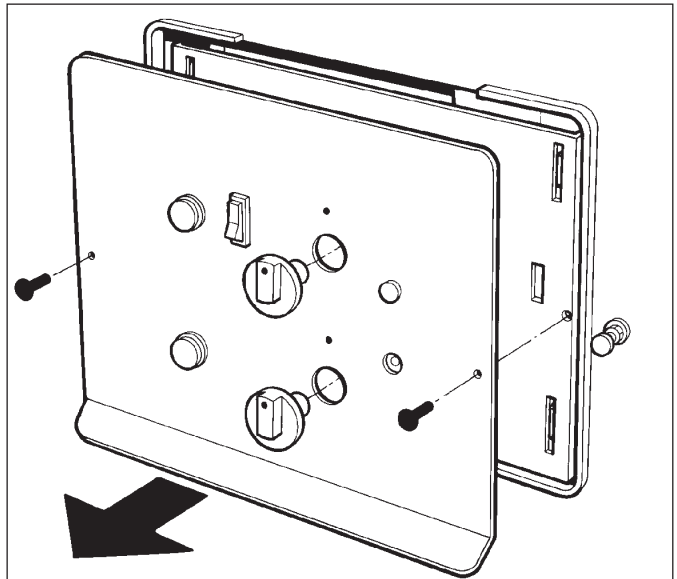

FIG. 15

DESN 514816

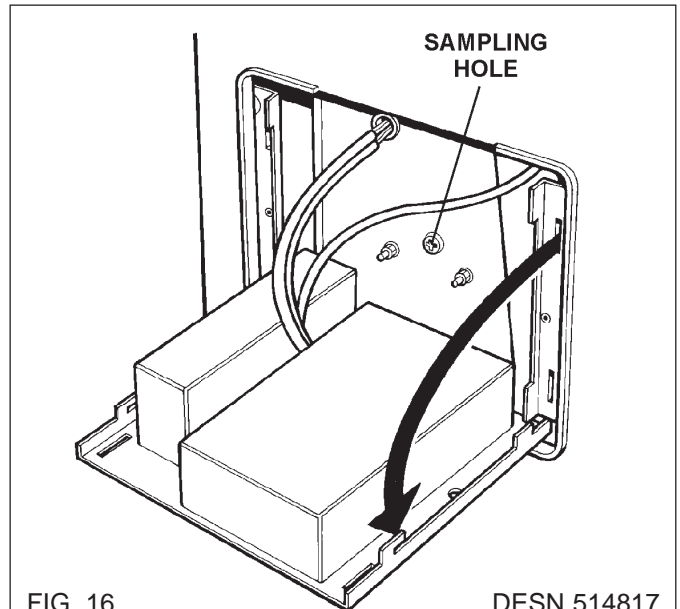

FIG. 16

DESN 514817

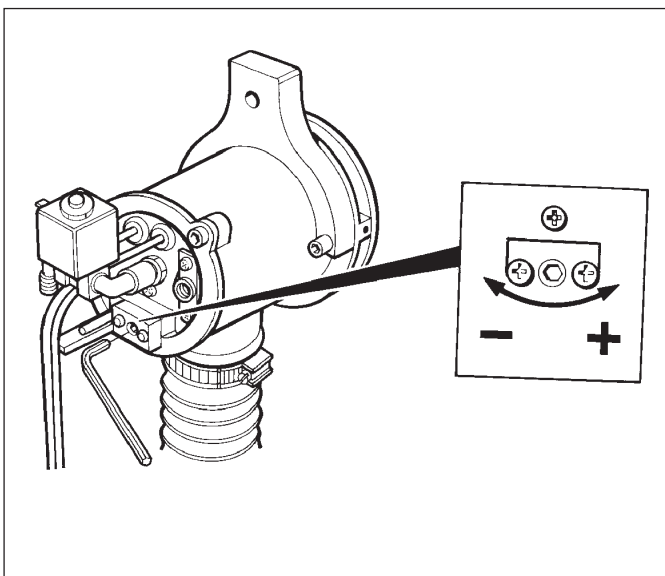

FIG. 14

DESN 514826

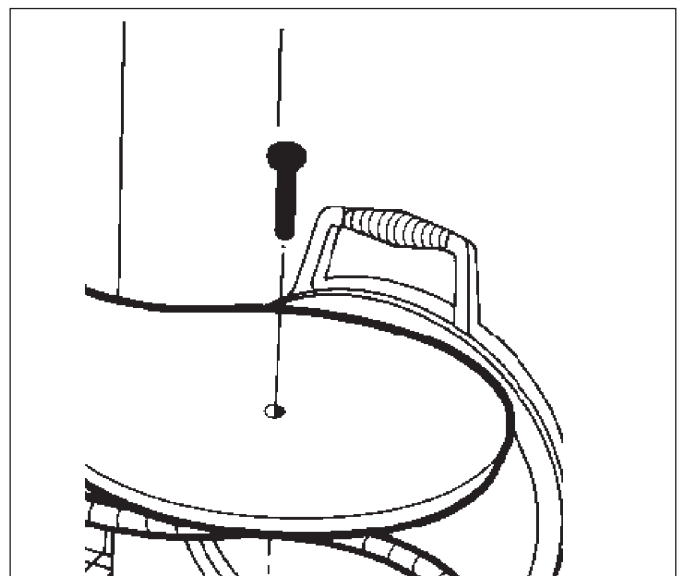

FIG. 17

DESN 514859

ANCILLARY CONTROLS CHECK

Before leaving the site, check the operation of programmer, control thermostat are working correctly and are capable of controlling the burner correctly.

Check the operation of both control boxes.

In the event of flame failure the control boxes should cut off the oil supply by closing the solenoid valves. The reset buttons will then be illuminated.

WAIT 30 SECONDS BEFORE RE-SETTING THE CONTROL BOX.

BOILER CONTROL CHECK

Check that:-

1. The boiler system is full of water and the valves are fully open.
2. The programmer is set to continuous heating and the heating switch set to heating.
3. Ensure that the electricity supply is ON, that the pump is running and the boiler thermostat is ON.

The boiler and pump should run until the system is hot and an inspection is made for water leaks.

The system should then be turned off and rapidly drained whilst still hot, with all manual and automatic valves in the open position. The system should then again be filled and cleared of all air locks. Whilst re-filling the system it is essential that a corrosion inhibitor is added to the feed water.

When all air locks have been removed and the system is hot the by-pass should be adjusted to ensure a quiet operation and the radiators balanced.

4. Allow the pump adjuster to maintain a "flow and return" differential temperature of 10°C - 14°C.

Checks must be made by the installer to see that the differential is obtained after the boiler "Flow" temperature is stabilised.

The system should be balanced by regulating the water flow rate through individual heat emitters to ensure satisfactory water temperature at each emitter.

5. When the water system reaches working temperature, check that the boiler thermostat operates satisfactorily.

INSTRUCT THE USER

1. Advise the User of the precautions necessary to prevent damage to the heating system and to the building in the event of the heating system being inoperative during frost conditions.
2. Advise the User that, for continued efficient and safe operation of the appliance, it is important that adequate servicing is carried out at regular 12 monthly intervals.
3. Hand the Operating instructions to the User and demonstrate the correct operation of the appliance and system controls.
4. Leave the Installation and Servicing instructions with the User.

Sealed Systems

SEALED SYSTEM REQUIREMENTS

SEE FIG. 18

- a. The installation must comply with the requirements of BS 6798 and BS 5449. Maximum water 82°C temperature.
- b. A safety set to operate at 3 bar (30lbf/In²) shall be fitted in the flow pipe close to the boiler. There must not be any valve between the safety valve and the boiler. The valve should be positioned on a discharge pipe fitted to prevent any discharge or creating a hazard to occupants or cause damage to electrical components and wiring.
- c. A pressure gauge covering at least the range 0 to 4 bar (0 to 60 lbf/In²) shall be fitted in the system, in a visible position.
- d. A diaphragm type expansion vessel, to BS 4814 shall be connected at a point in the return pipe close to the boiler. The vessel must be chosen to suit the volume of water in the cistern and the system charge must not be less than the static head at the point of connection. Further details can be obtained from 'British Gas Specification for Domestic Wet Central Heating Systems Part 3 Sealed Systems'.

Safety Valve Setting	3.0 bar	
Vessel charge and initial system pressure	0.5 bar	1.0 bar
Multiplying Factor	0.09	0.16
Expansion Vessel volume (litres) = System volume Vs x factor	L Vs x 0.09	L Vs x 0.16

Vs = System Volume Litres

- e. The hot water cylinder shall be either the indirect coil type or a cylinder fitted with a calorifer which is suitable for the system pressure.
- f. **The Make-Up System**
Provision shall be made for replacing the lost water from the system by either of the following methods:
 - a) From a make-up vessel or tank, and connected through a non-return valve to the system on the return side of the hot water cylinder or return side of all heat emitters or radiators.
 - b) Where access to a make-up vessel would be difficult, by a remote automatic pressurisation and make-up unit.

g. Mains Connection

There shall be no connection to mains water supply or to the water storage cistern supplying domestic hot water, even though a non-return valve may be fitted, without the approval of the local water authority.

h. The Filling Point

The system shall be fitted with a filling point at a low level, and be used in accordance with the local water authority requirement, and shall generally have a stop valve to BS 1010.

i. Commissioning - General

The system shall be filled by water by a method acceptable to the Local Water Authority.

Check the operation of the safety valve manually.

Test the operation of the high limit cut-out according to the manufacturers instructions.

After flushing and re-filling the system either:-

- (a) If a make-up vessel is filled release water from the safety valve until the level in the make-up bottle falls visibly, then top up the make-up bottle.
- (b) If there is no make-up vessel either release or introduce water until the designed cold water pressure level is reached.

COMMISSIONING

Follow the commissioning instructions as for open vented systems. See Section Commissioning Instructions with the following additions:-

Fill the system until the pressure gauge reads 1.5 bar (22lbf/In²). Clear any airlocks and check for water soundness.

Check the operation of the safety valve, by allowing the water pressure to rise until the valve opens. The valve should open within ±0.3 bar (±4.35 lbf/In²) of the pre-set pressure. If this is not possible conduct a manual check and test.

Release cold water for initial filling pressure.

Any set pointer gauge should be set to coincide with the recommended filling pressure.

Typical Sealed System

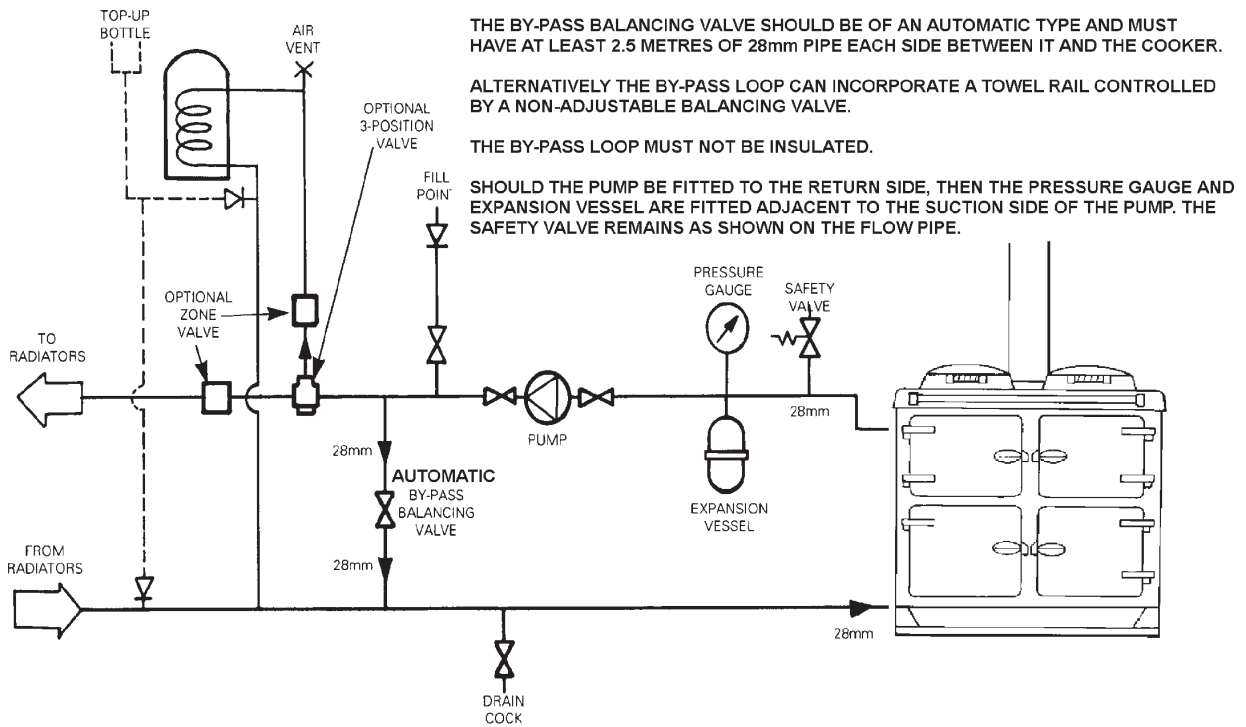

Typical Open Vented System

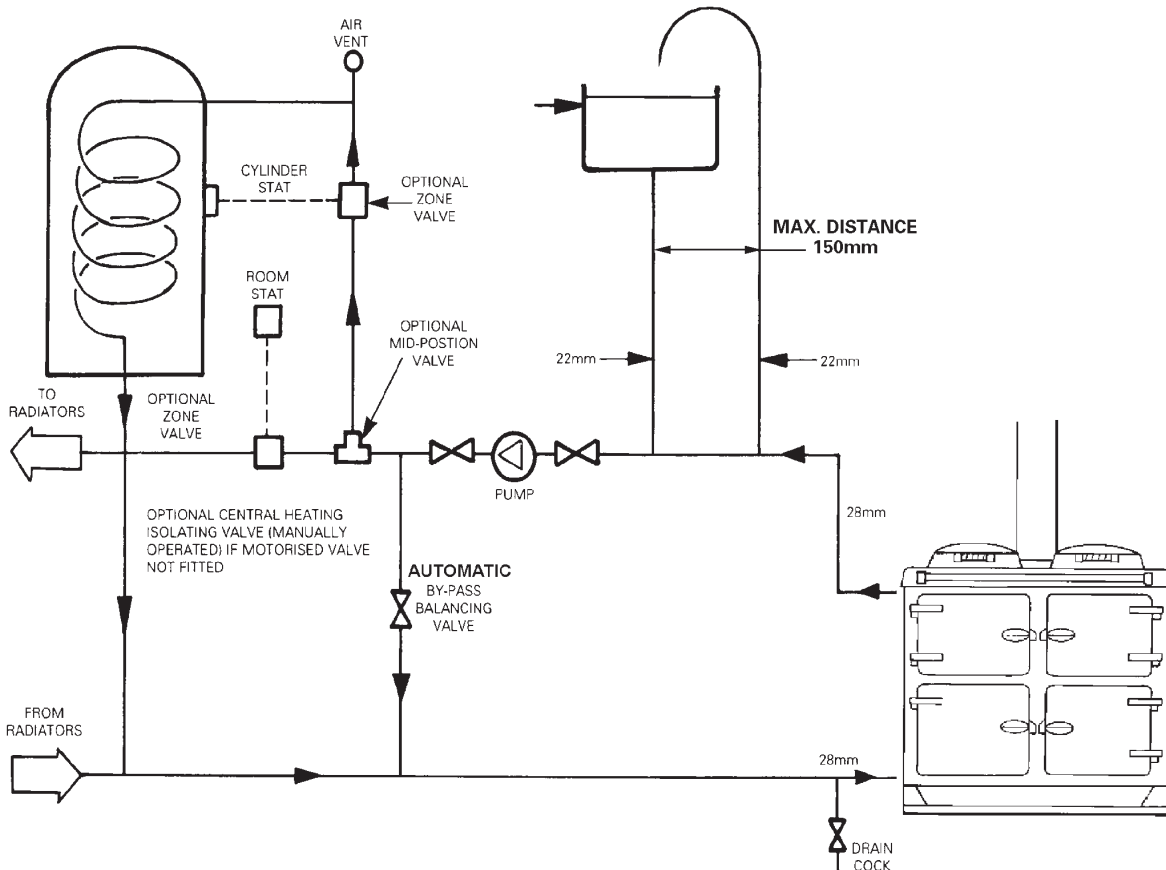

FIG. 18

For further advice or information contact your
local distributor/stockist

With Waterford Stanley's policy of continuous
product improvement, the Company reserves the
right to change specifications and make
modifications to the appliance described at any
time.



Supplied by
Waterford Stanley
Units 401-403
IDA Industrial Estate
Cork Road
Waterford
Ireland